



ROHDE & SCHWARZ

Test and Measurement
Division

Service Manual

Handheld Spectrum Analyzer

R&S[®] FSH

1145.5850.03

1145.5850.06

1145.5850.13

1145.5850.23

1145.5850.26

Dear Customer,

R&S® is a registered trademark of Rohde & Schwarz GmbH & Co. KG.
Trade names are trademarks of the owners.

Contents

Safety Instructions

Certificate of Quality

Spare Parts Express Service

List of R&S Representatives

Contents of Manuals for Spectrum Analyzer R&S FSH

Service and Repair

1 Performance Test	1.1
Test Instructions	1.1
Measuring Equipment and Accessories	1.1
Performance Test	1.2
Checking the frequency accuracy	1.2
Checking the level accuracy and the frequency response.....	1.3
Checking the accuracy of the RF attenuator	1.5
Checking the accuracy of the IF gain setting	1.6
Checking the displayed average noise floor.....	1.7
Checking the phase noise	1.8
Checking the display linearity	1.9
Performance Test Tracking Generator	1.11
Checking output level / frequency response	1.11
Performance Test Report	1.12
Performance Test Report Tracking Generator	1.19

2 Adjustment	2.1
Quick Verification	2.1
Measurement Equipment and Accessories for Quick Verification	2.2
Verifying on/off functionality.....	2.2
Verifying power and AF connections.....	2.2
Verifying the display.....	2.3
Verifying the level and noise.....	2.3
Verify the tracking generator output level.....	2.4
Adjustment functions	2.4
Adjustment	2.5
Adjustment Instructions	2.5
Measurement Equipment and Accessories	2.6
Adjusting the reference frequency accuracy	2.6
Adjusting the level accuracy	2.7
Frequency Response Correction	2.8

3 Repair	3.1
Instrument Design and Functional Description	3.1
Description of the block diagram	3.2
Attenuator	3.2
RF to IF conversion	3.2
Tracking generator (Model 1145.5850.13/23/26 only)	3.4
RF/IF control	3.4
Mainboard	3.4
Power and battery management	3.4
Processing of measured data detectors	3.5
Resolution bandwidths (RBW)	3.5
Video bandwidths (VBW)	3.5
Detectors	3.6
Keypad control	3.6
Serial optical interface	3.6
Power sensor	3.6
Color LCD module	3.6
Module Replacement	3.7
Overview of the modules	3.9
Opening the instrument	3.10
Closing the instrument	3.10
Replacing the battery	3.11
Replacing the housing	3.12
Replacing the front unit for R&S FSH	3.13
Replacing the Color LCD Module	3.14
Replacing the RF/IF module	3.15
Replacing the mainboard	3.16
Replacing the N connector	3.17
Replacing the binder and BNC connector block	3.18
Replacing the power/audio connections	3.19
Replacing a cable from the cable set	3.20
Troubleshooting	3.21
Overview of errors, causes, and possible corrective actions	3.22
Troubleshooting problems in switching on the instrument	3.22

4 Software Updates / Installing Options	4.1
Installing New R&S FSH Software	4.1
Installing the Options	4.1
5 Documents	5.1
Shipping of Instrument and Ordering of Spare Parts	5.1
Shipping of instrument.....	5.1
Shipping of a module.....	5.1
Ordering spare parts.....	5.2
Refurbished modules.....	5.2
Return of defective replaced modules.....	5.2
Spare Parts	5.3



Before putting the product into operation for the first time, make sure to read the following



Safety Instructions

Rohde & Schwarz makes every effort to keep the safety standard of its products up to date and to offer its customers the highest possible degree of safety. Our products and the auxiliary equipment required for them are designed and tested in accordance with the relevant safety standards. Compliance with these standards is continuously monitored by our quality assurance system. This product has been designed and tested in accordance with the EC Certificate of Conformity and has left the manufacturer's plant in a condition fully complying with safety standards. To maintain this condition and to ensure safe operation, observe all instructions and warnings provided in this manual. If you have any questions regarding these safety instructions, Rohde & Schwarz will be happy to answer them.

Furthermore, it is your responsibility to use the product in an appropriate manner. This product is designed for use solely in industrial and laboratory environments or in the field and must not be used in any way that may cause personal injury or property damage. You are responsible if the product is used for an intention other than its designated purpose or in disregard of the manufacturer's instructions. The manufacturer shall assume no responsibility for such use of the product.

The product is used for its designated purpose if it is used in accordance with its operating manual and within its performance limits (see data sheet, documentation, the following safety instructions). Using the products requires technical skills and knowledge of English. It is therefore essential that the products be used exclusively by skilled and specialized staff or thoroughly trained personnel with the required skills. If personal safety gear is required for using Rohde & Schwarz products, this will be indicated at the appropriate place in the product documentation.

Symbols and safety labels

Observe operating instructions	Weight indication for units >18 kg	Danger of electric shock	Warning! Hot surface	PE terminal	Ground	Ground terminal	Attention! Electrostatic sensitive devices

I C					
Supply voltage ON/OFF	Standby indication	Direct current (DC)	Alternating current (AC)	Direct/alternating current (DC/AC)	Device fully protected by double/reinforced insulation

Safety Instructions

Observing the safety instructions will help prevent personal injury or damage of any kind caused by dangerous situations. Therefore, carefully read through and adhere to the following safety instructions before putting the product into operation. It is also absolutely essential to observe the additional safety instructions on personal safety that appear in other parts of the documentation. In these safety instructions, the word "product" refers to all merchandise sold and distributed by Rohde & Schwarz, including instruments, systems and all accessories.

Tags and their meaning

DANGER	This tag indicates a safety hazard with a high potential of risk for the user that can result in death or serious injuries.
WARNING	This tag indicates a safety hazard with a medium potential of risk for the user that can result in death or serious injuries.
CAUTION	This tag indicates a safety hazard with a low potential of risk for the user that can result in slight or minor injuries.
ATTENTION	This tag indicates the possibility of incorrect use that can cause damage to the product.
NOTE	This tag indicates a situation where the user should pay special attention to operating the product but which does not lead to damage.

Basic safety instructions

1. The product may be operated only under the operating conditions and in the positions specified by the manufacturer. Its ventilation must not be obstructed during operation. Unless otherwise specified, the following requirements apply to Rohde & Schwarz products: IP protection 2X, pollution severity 2, overvoltage category 2, use only in enclosed spaces, max. operation altitude max. 2000 m.
2. Applicable local or national safety regulations and rules for the prevention of accidents must be observed in all work performed. The product may be opened only by authorized, specially trained personnel. Prior to performing any work on the product or opening the product, the instrument must be disconnected from the supply network. Any adjustments, replacements of parts, maintenance or repair must be carried out only by technical personnel authorized by Rohde & Schwarz. Only original parts may be used for replacing parts relevant to safety (e.g. power switches, power transformers, fuses). A safety test must always be performed after parts relevant to safety have been replaced
3. As with all industrially manufactured goods, the use of substances that induce an allergic reaction (allergens) such as aluminum cannot be generally excluded. If you develop an allergic reaction (such as a skin rash, frequent sneezing, red eyes or respiratory difficulties), consult a physician immediately to determine the cause.
4. Depending on the function, certain products such as RF radio equipment can produce an elevated level of electromagnetic radiation. Considering that unborn life requires increased protection, pregnant women should be protected by appropriate measures. Persons with pacemakers may also be endangered by electromagnetic radiation. The employer is required to assess workplaces where there is a special risk of exposure to radiation and, if necessary, take measures to avert the danger.

Safety Instructions

5. Operating the products requires special training and intense concentration. Disabled persons should not use the products unless it is made certain that their disability has no adverse effects while they are operating the products.
6. Prior to switching on the product, it must be ensured that the nominal voltage setting on the product matches the nominal voltage of the AC supply network. If a different voltage is to be set, the power fuse of the product may have to be changed accordingly.
7. In the case of products of safety class I with movable power cord and connector, operation is permitted only on sockets with earthing contact and protective earth connection.
8. Intentionally breaking the protective earth connection either in the feed line or in the product itself is not permitted. Doing so can result in the danger of an electric shock from the product. If extension cords or connector strips are implemented, they must be checked on a regular basis to ensure that they are safe to use.
9. If the product has no power switch for disconnection from the AC supply, the plug of the connecting cable is regarded as the disconnecting device. In such cases, it must be ensured that the power plug is easily reachable and accessible at all times (length of connecting cable approx. 2 m). Functional or electronic switches are not suitable for providing disconnection from the AC supply. If products without power switches are integrated in racks or systems, a disconnecting device must be provided at the system level.
10. Never use the product if the power cable is damaged. By taking appropriate safety measures and carefully laying the power cable, ensure that the cable cannot be damaged and that no one can be hurt by e.g. tripping over the cable or suffering an electric shock.
11. The product may be operated only from TN/TT supply networks fused with max. 16 A.
12. Do not insert the plug into sockets that are dusty or dirty. Insert the plug firmly and all the way into the socket. Otherwise this can result in sparks, fire and/or injuries.
13. Do not overload any sockets, extension cords or connector strips; doing so can cause fire or electric shocks.
14. For measurements in circuits with voltages $V_{rms} > 30 V$, suitable measures (e.g. appropriate measuring equipment, fusing, current limiting, electrical separation, insulation) should be taken to avoid any hazards.
15. Ensure that the connections with information technology equipment comply with IEC950/EN60950.
16. Never remove the cover or part of the housing while you are operating the product. This will expose circuits and components and can lead to injuries, fire or damage to the product.
17. If a product is to be permanently installed, the connection between the PE terminal on site and the product's PE conductor must be made first before any other connection is made. The product may be installed and connected only by a skilled electrician.
18. For permanently installed equipment without built-in fuses, circuit breakers or similar protective devices, the supply circuit must be fused in such a way that suitable protection is provided for users and products.
19. Do not insert any objects into the openings in the housing that are not designed for this purpose. Never pour any liquids onto or into the housing. This can cause short circuits inside the product and/or electric shocks, fire or injuries.
20. Use suitable overvoltage protection to ensure that no overvoltage (such as that caused by a thunderstorm) can reach the product. Otherwise the operating personnel will be endangered by electric shocks.

Safety Instructions

21. Rohde & Schwarz products are not protected against penetration of water, unless otherwise specified (see also safety instruction 1.). If this is not taken into account, there exists the danger of electric shock or damage to the product, which can also lead to personal injury.
22. Never use the product under conditions in which condensation has formed or can form in or on the product, e.g. if the product was moved from a cold to a warm environment.
23. Do not close any slots or openings on the product, since they are necessary for ventilation and prevent the product from overheating. Do not place the product on soft surfaces such as sofas or rugs or inside a closed housing, unless this is well ventilated.
24. Do not place the product on heat-generating devices such as radiators or fan heaters. The temperature of the environment must not exceed the maximum temperature specified in the data sheet.
25. Batteries and storage batteries must not be exposed to high temperatures or fire. Keep batteries and storage batteries away from children. If batteries or storage batteries are improperly replaced, this can cause an explosion (warning: lithium cells). Replace the battery or storage battery only with the matching Rohde & Schwarz type (see spare parts list). Batteries and storage batteries are hazardous waste. Dispose of them only in specially marked containers. Observe local regulations regarding waste disposal. Do not short-circuit batteries or storage batteries.
26. Please be aware that in the event of a fire, toxic gases that may be hazardous to your health may escape from the product.
27. Please be aware of the weight of the product. Be careful when moving it; otherwise you may injure your back or other parts of your body.
28. Do not place the product on surfaces, vehicles, cabinets or tables that for reasons of weight or stability are unsuitable for this purpose. Always follow the manufacturer's installation instructions when installing the product and fastening it to objects or structures (e.g. walls and shelves).
29. If you use the product in a vehicle, it is the sole responsibility of the driver to drive the vehicle safely. Adequately secure the product in the vehicle to prevent injuries or other damage in the event of an accident. Never use the product in a moving vehicle if doing so could distract the driver of the vehicle. The driver is always responsible for the safety of the vehicle; the manufacturer assumes no responsibility for accidents or collisions.
30. If a laser product (e.g. a CD/DVD drive) is integrated in a Rohde & Schwarz product, do not use any other settings or functions than those described in the documentation. Otherwise this may be hazardous to your health, since the laser beam can cause irreversible damage to your eyes. Never try to take such products apart, and never look into the laser beam.



Por favor lea imprescindiblemente antes de la primera puesta en funcionamiento las siguientes informaciones de seguridad



Informaciones de seguridad

Es el principio de Rohde&Schwarz de tener a sus productos siempre al día con los standards de seguridad y de ofrecer a sus clientes el máximo grado de seguridad. Nuestros productos y todos los equipos adicionales son siempre fabricados y examinados según las normas de seguridad vigentes. Nuestra sección de gestión de la seguridad de calidad controla constantemente que sean cumplidas estas normas. Este producto ha sido fabricado y examinado según el comprobante de conformidad adjunto según las normas de la CE y ha salido de nuestra planta en estado impecable según los standards técnicos de seguridad. Para poder preservar este estado y garantizar un funcionamiento libre de peligros, deberá el usuario atenerse a todas las informaciones, informaciones de seguridad y notas de alerta. Rohde&Schwarz está siempre a su disposición en caso de que tengan preguntas referentes a estas informaciones de seguridad.

Además queda en la responsabilidad del usuario utilizar el producto en la forma debida. Este producto solamente fue elaborado para ser utilizado en la industria y el laboratorio o para fines de campo y de ninguna manera deberá ser utilizado de modo que alguna persona/cosa pueda ser dañada. El uso del producto fuera de sus fines definidos o despreciando las informaciones de seguridad del fabricante queda en la responsabilidad del usuario. El fabricante no se hace en ninguna forma responsable de consecuencias a causa del maluso del producto.

Se parte del uso correcto del producto para los fines definidos si el producto es utilizado dentro de las instrucciones del correspondiente manual del uso y dentro del margen de rendimiento definido (ver hoja de datos, documentación, informaciones de seguridad que siguen). El uso de los productos hace necesarios conocimientos profundos y el conocimiento del idioma inglés. Por eso se deberá tener en cuenta de exclusivamente autorizar para el uso de los productos a personas péritas o debidamente minuciosamente instruidas con los conocimientos citados. Si fuera necesaria indumentaria de seguridad para el uso de productos de R&S, encontrará la información debida en la documentación del producto en el capítulo correspondiente.

Símbolos y definiciones de seguridad

Ver manual de instrucciones del uso	Informaciones para maquinaria con un peso de > 18kg	Peligro de golpe de corriente	¡Cuidado! Superficie caliente	Conexión a conductor protector	Conexión a tierra	Conexión a masa conductora	¡Cuidado! Elementos de construcción con peligro de carga electrostática

potencia EN MARCHA/PARADA	Indicación Stand-by	Corriente continua DC	Corriente alterna AC	Corriente continua/alterna DC/AC	El aparato está protegido en su totalidad por un aislamiento de doble refuerzo

Informaciones de seguridad

Tener en cuenta las informaciones de seguridad sirve para tratar de evitar daños y peligros de toda clase. Es necesario de que se lean las siguientes informaciones de seguridad concienzudamente y se tengan en cuenta debidamente antes de la puesta en funcionamiento del producto. También deberán ser tenidas en cuenta las informaciones para la protección de personas que encontrarán en otro capítulo de esta documentación y que también son obligatorias de seguir. En las informaciones de seguridad actuales hemos juntado todos los objetos vendidos por Rohde&Schwarz bajo la denominación de „producto“, entre ellos también aparatos, instalaciones así como toda clase de accesorios.

Palabras de señal y su significado

PELIGRO	Indica un punto de peligro con gran potencial de riesgo para el usuario. Punto de peligro que puede llevar hasta la muerte o graves heridas.
ADVERTENCIA	Indica un punto de peligro con un potencial de riesgo mediano para el usuario. Punto de peligro que puede llevar hasta la muerte o graves heridas .
CUIDADO	Indica un punto de peligro con un potencial de riesgo pequeño para el usuario. Punto de peligro que puede llevar hasta heridas leves o pequeñas
ATENCIÓN	Indica la posibilidad de utilizar mal el producto y a consecuencia dañarlo.
INFORMACIÓN	Indica una situación en la que deberían seguirse las instrucciones en el uso del producto, pero que no consecuentemente deben de llevar a un daño del mismo.

Informaciones de seguridad elementales

1. El producto solamente debe ser utilizado según lo indicado por el fabricante referente a la situación y posición de funcionamiento sin que se obstruya la ventilación. Si no se convino de otra manera, es para los productos R&S válido lo que sigue:
modo de protección IP 2X, grado de suciedad 2, categoría de sobrecarga eléctrica 2, utilizar solamente en estancias interiores, utilización hasta 2000 m sobre el nivel del mar.
2. En todos los trabajos deberán ser tenidas en cuenta las normas locales de seguridad de trabajo y de prevención de accidentes. El producto solamente debe de ser abierto por personal périto autorizado. Antes de efectuar trabajos en el producto o abrirlo deberá este ser desconectado de la corriente. El ajuste, el cambio de partes, la manutención y la reparación deberán ser solamente efectuadas por electricistas autorizados por R&S. Si se reponen partes con importancia para los aspectos de seguridad (por ejemplo el enchufe, los transformadores o los fusibles), solamente podrán ser sustituidos por partes originales. Después de cada recambio de partes elementales para la seguridad deberá ser efectuado un control de seguridad (control a primera vista, control de conductor protector, medición de resistencia de aislamiento, medición de medición de la corriente conductora, control de funcionamiento).
3. Como en todo producto de fabricación industrial no puede ser excluido en general de que se produzcan al usarlo elementos que puedan generar alergias, los llamados elementos alergénicos (por ejemplo el aluminio). Si se produjeran en el trato con productos R&S reacciones alérgicas, como por ejemplo urticaria, estornudos frecuentes, irritación de la conjuntiva o dificultades al respirar, se deberá consultar inmediatamente a un médico para averiguar los motivos de estas reacciones.

Informaciones de seguridad

4. Ciertos productos, como por ejemplo las instalaciones de radiación HF, pueden a causa de su función natural, emitir una radiación electromagnética aumentada. En vista a la protección de la vida en desarrollo deberían ser protegidas personas embarazadas debidamente. También las personas con un bypass pueden correr peligro a causa de la radiación electromagnética. El empresario está comprometido a valorar y señalar áreas de trabajo en las que se corra un riesgo de exposición a radiaciones aumentadas de riesgo aumentado para evitar riesgos.
5. La utilización de los productos requiere instrucciones especiales y una alta concentración en el manejo. Personas minusválidas solamente deberán utilizar estos productos si está por seguro de que a causa de su handicap no podrá surgir ninguna restricción en el manejo del producto.
6. Antes de la puesta en marcha del producto se deberá tener por seguro de que la tensión preseleccionada en el producto equivalga a la de la red de distribución. Si es necesario cambiar la preselección de la tensión también se deberán en caso de cambio cambiar los fusibles correspondientes del producto.
7. Productos de la clase de seguridad I con alimentación móvil y enchufe individual de producto solamente deberán ser conectados para el funcionamiento a tomas de corriente de contacto de seguridad y con conductor protector conectado.
8. Queda prohibida toda clase de interrupción intencionada del conductor protector, tanto en la toma de corriente como en el mismo producto ya que puede tener como consecuencia el peligro de golpe de corriente por el producto. Si se utilizaran cables o enchufes de extensión se deberá poner al seguro, que es controlado su estado técnico de seguridad.
9. Si el producto no está equipado con un interruptor para desconectarlo de la red, se deberá considerar el enchufe del cable de distribución como interruptor. En estos casos deberá asegurarse de que el enchufe sea de fácil acceso y manejo (medida del cable de distribución aproximadamente 2 m). Los interruptores de función o electrónicos no son aptos para el corte de la red eléctrica. Si los productos sin interruptor están integrados en construcciones o instalaciones, se deberá instalar el interruptor al nivel de la instalación.
10. No utilice nunca el producto si está dañado el cable eléctrico. Asegure a través de las medidas de protección y de instalación adecuadas de que el cable de eléctrico no pueda ser dañado o de que nadie pueda ser dañado por él, por ejemplo al tropezar o por un golpe de corriente.
11. Solamente está permitido el funcionamiento en redes de distribución TN/TT aseguradas con fusibles de como máximo 16 A.
12. Nunca conecte el enchufe en tomas de corriente sucias o llenas de polvo. Introduzca el enchufe por completo y fuertemente en la toma de corriente. Si no tiene en consideración estas indicaciones se arriesga a que se originen chispas, fuego y/o heridas.
13. No sobrecargue las tomas de corriente, los cables de extensión o los enchufes de extensión ya que esto pudiera causar fuego o golpes de corriente.
14. En las mediciones en circuitos de corriente con una tensión de entrada de $U_{eff} > 30 \text{ V}$ se deberá tomar las precauciones debidas para impedir cualquier peligro (por ejemplo medios de medición adecuados, seguros, limitación de tensión, corte protector, aislamiento etc.).
15. En caso de conexión con aparatos de la técnica informática se deberá tener en cuenta que estos cumplan los requisitos de la EC950/EN60950.
16. Nunca abra la tapa o parte de ella si el producto está en funcionamiento. Esto pone a descubierto los cables y componentes eléctricos y puede causar heridas, fuego o daños en el producto.
17. Si un producto es instalado fijamente en un lugar, se deberá primero conectar el conductor protector fijo con el conductor protector del aparato antes de hacer cualquier otra conexión. La instalación y la conexión deberán ser efectuadas por un electricista especializado.

Informaciones de seguridad

18. En caso de que los productos que son instalados fijamente en un lugar sean sin protector implementado, autointerruptor o similares objetos de protección, deberá la toma de corriente estar protegida de manera que los productos o los usuarios estén suficientemente protegidos.
19. Por favor, no introduzca ningún objeto que no esté destinado a ello en los orificios de la caja del aparato. No vierta nunca ninguna clase de líquidos sobre o en la caja. Esto puede producir corto circuitos en el producto y/o puede causar golpes de corriente, fuego heridas.
20. Asegúrese con la protección adecuada de que no pueda originarse en el producto una sobrecarga por ejemplo a causa de una tormenta. Si no se verá el personal que lo utilice expuesto al peligro de un golpe de corriente.
21. Los productos R&S no están protegidos contra el agua si no es que exista otra indicación, ver también punto 1. Si no se tiene en cuenta esto se arriesga el peligro de golpe de corriente o de daños en el producto lo cual también puede llevar al peligro de personas.
22. No utilice el producto bajo condiciones en las que pueda producirse y se hayan producido líquidos de condensación en o dentro del producto como por ejemplo cuando se desplaza el producto de un lugar frío a un lugar caliente.
23. Por favor no cierre ninguna ranura u orificio del producto, ya que estas son necesarias para la ventilación e impiden que el producto se caliente demasiado. No pongan el producto encima de materiales blandos como por ejemplo sofás o alfombras o dentro de una caja cerrada, si esta no está suficientemente ventilada.
24. No ponga el producto sobre aparatos que produzcan calor, como por ejemplo radiadores o calentadores. La temperatura ambiental no debe superar la temperatura máxima especificada en la hoja de datos.
25. Baterías y acumuladores no deben de ser expuestos a temperaturas altas o al fuego. Guardar baterías y acumuladores fuera del alcance de los niños. Si las baterías o los acumuladores no son cambiados con la debida atención existirá peligro de explosión (atención células de Litio). Cambiar las baterías o los acumuladores solamente por los del tipo R&S correspondiente (ver lista de piezas de recambio). Baterías y acumuladores son desechos problemáticos. Por favor tirelos en los recipientes especiales para este fin. Por favor tengan en cuenta las prescripciones nacionales de cada país referente al tratamiento de desechos. Nunca sometan a las baterías o acumuladores a un corto circuito.
26. Tengan en consideración de que en caso de un incendio pueden escaparse gases tóxicos del producto, que pueden causar daños a la salud.
27. Por favor tengan en cuenta el peso del producto. Muevanlo cuidadosamente ya que el peso puede causar lesiones de la espalda u otros daños físicos.
28. No sitúe el producto encima de superficies, vehículos, estantes o mesas, que por sus características de peso o de estabilidad no sean aptas para él. Siga siempre las instrucciones de instalación del fabricante cuando instale y asegure el producto en objetos o estructuras (por ejemplo paredes y estantes).
29. Si llega a utilizar el producto dentro de un vehículo, queda en la responsabilidad absoluta del conductor que conducir el vehículo de manera segura. Asegure el producto dentro del vehículo debidamente para evitar en caso de un accidente las lesiones u otra clase de daños. No utilice nunca el producto dentro de un vehículo en movimiento si esto pudiera distraer al conductor. Siempre queda en la responsabilidad absoluta del conductor la seguridad del vehículo y el fabricante no asumirá ninguna clase de responsabilidad por accidentes o colisiones.
30. Dado el caso de que esté integrado un producto de laser en un producto R&S (por ejemplo CD/DVD-ROM) no utilice otras instalaciones o funciones que las descritas en la documentación. De otra manera pondrá en peligro su salud, ya que el rayo laser puede dañar irreversiblemente sus ojos. Nunca trate de descomponer estos productos. Nunca mire dentro del rayo laser.

Certified Quality System

DIN EN ISO 9001 : 2000
DIN EN 9100 : 2003
DIN EN ISO 14001 : 1996

DQS REG. NO 001954 QM/ST UM

QUALITÄTSZERTIFIKAT

Sehr geehrter Kunde,

Sie haben sich für den Kauf eines Rohde & Schwarz-Produktes entschieden. Hiermit erhalten Sie ein nach modernsten Fertigungsmethoden hergestelltes Produkt. Es wurde nach den Regeln unseres Managementsystems entwickelt, gefertigt und geprüft.

Das Rohde & Schwarz Managementsystem ist zertifiziert nach:

DIN EN ISO 9001:2000
DIN EN 9100:2003
DIN EN ISO 14001:1996

CERTIFICATE OF QUALITY

Dear Customer,

you have decided to buy a Rohde & Schwarz product. You are thus assured of receiving a product that is manufactured using the most modern methods available. This product was developed, manufactured and tested in compliance with our quality management system standards.

The Rohde & Schwarz quality management system is certified according to:

DIN EN ISO 9001:2000
DIN EN 9100:2003
DIN EN ISO 14001:1996

CERTIFICAT DE QUALITÉ

Cher Client,

vous avez choisi d'acheter un produit Rohde & Schwarz. Vous disposez donc d'un produit fabriqué d'après les méthodes les plus avancées. Le développement, la fabrication et les tests respectent nos normes de gestion qualité.

Le système de gestion qualité de Rohde & Schwarz a été homologué conformément aux normes:

DIN EN ISO 9001:2000
DIN EN 9100:2003
DIN EN ISO 14001:1996



ROHDE & SCHWARZ

Spare Parts Express Service

Phone: +49 89 4129 - 12465

Fax: +49 89 41 29 - 13306

E-mail: werner.breidling@rsd.rohde-schwarz.com

In case of urgent spare parts requirements for this Rohde & Schwarz unit, please contact our spare parts express service.

Outside business hours, please leave us a message or send a fax or e-mail. We shall contact you promptly.

Adressen/Addresses

FIRMENSITZ/HEADQUARTERS

(Tel) Phone
(Fax) Fax
E-mail

Rohde & Schwarz GmbH & Co. KG
Mühlendorfstraße 15 · D-81671 München
Postfach 80 14 69 · D-81614 München

(Tel) +49 (89) 41 29-0
(Fax) +49 89 4129-121 64
info@rohde-schwarz.com

WERKE/PLANTS

Rohde & Schwarz Messgerätebau GmbH
Riedbachstraße 58 · D-87700 Memmingen
Postfach 1652 · D-87686 Memmingen

(Tel) +49 (8331) 108-0
(Fax) +49 (8331) 108-11 24
info.rsdbm@rohde-schwarz.com

Rohde & Schwarz GmbH & Co. KG
Werk Teisnach
Kaikenrieder Straße 27 · D-94244 Teisnach
Postfach 1149 · D-94240 Teisnach

(Tel) +49 (9923) 857-0
(Fax) +49 (9923) 857-11 74
info.rsdt@rohde-schwarz.com

Rohde & Schwarz GmbH & Co. KG
Dienstleistungszentrum Köln
Graf-Zeppelin-Straße 18 · D-51147 Köln
Postfach 98 02 60 · D-51130 Köln

(Tel) +49 (2203) 49-0
(Fax) +49 (2203) 49 51-229
info.rsd@rohde-schwarz.com
schwarz.com-service.rsd@rohde-schwarz.com

TOCHTERUNTERNEHMEN/SUBSIDIARIES

Rohde & Schwarz Vertriebs-GmbH
Mühlendorfstraße 15 · D-81671 München
Postfach 80 14 69 · D-81614 München

(Tel) +49 (89) 41 29-137 74
(Fax) +49 (89) 41 29-137 77
customersupport@rohde-schwarz.com

Rohde & Schwarz International GmbH
Mühlendorfstraße 15 · D-81671 München
Postfach 80 14 60 · D-81614 München

(Tel) +49 (89) 41 29-129 84
(Fax) +49 (89) 41 29-120 50
info.rusis@rohde-schwarz.com

Rohde & Schwarz Engineering and Sales GmbH
Mühlendorfstraße 15 · D-81671 München
Postfach 80 14 29 · D-81614 München

(Tel) +49 (89) 41 29-137 11
(Fax) +49 (89) 41 29-137 23
info.rse@rohde-schwarz.com

R&S BICK Mobilfunk GmbH
Fritz-Hahne-Str. 7 · D-31848 Bad Münder
Postfach 2062 · D-31844 Bad Münder

(Tel) +49 (5042) 998-0
(Fax) +49 (5042) 998-105
info.rsbeck@rohde-schwarz.com

Rohde & Schwarz FTK GmbH
Wendenschlossstraße 168, Haus 28
D-12557 Berlin

(Tel) +49 (30) 658 91-122
(Fax) +49 (30) 655 50-221
info.ftk@rohde-schwarz.com

Rohde & Schwarz SIT GmbH
Agastraße 3
D-12489 Berlin

(Tel) +49 (30) 658 84-0
(Fax) +49 (30) 658 84-183
info.sit@rohde-schwarz.com

R&S Systems GmbH
Graf-Zeppelin-Straße 18 · D-51147 Köln
Postfach 98 02 60 · D-51130 Köln

(Tel) +49 (2203) 49-5 23 25
(Fax) +49 (2203) 49-5 23 36
info.rssys@rohde-schwarz.com

ADRESSEN WELTWEIT/ADDRESSES WORLDWIDE

Albania siehe/see Austria

Algeria Rohde & Schwarz
Bureau d'Alger
5B Place de Laperrine
16035 Hydra-Alger

(Tel) +213 (21) 48 20 18
(Fax) +213 (21) 69 46 08

Antilles (Neth.) siehe / see Mexico

Argentina Precision Electronica S.R.L.
Av. Pde Julio A. Roca 710 - 6° Piso
1067 Buenos Aires

(Tel) +541 (14) 331 10 67
(Fax) +541 (14) 334 51 11
alberto.lombardi@prec-elec.com.ar

Australia Rohde & Schwarz (Australia) Pty. Ltd.
Sales Support
Unit 6
2-8 South Street
Rydalmere, N.S.W. 2116

(Tel) +61 (2) 88 45 41 00
(Fax) +61 (2) 96 38 39 88
sales@rsa.us.rohde-schwarz.com

Austria Rohde & Schwarz-Österreich Ges.m.b.H.
Am Europlatz 3
Gebäude B
1120 Wien

(Tel) +43 (1) 602 61 41-0
(Fax) +43 (1) 602 61 41-14
rs-austria@rsoe.rohde-schwarz.com

Azerbaijan Rohde & Schwarz Azerbaijan
Liaison Office Baku
ISR Plaza, 5th floor
340 Nizami Str.
370000 Baku

(Tel) +994 (12) 93 31 38
(Fax) +994 (12) 93 03 14
rs-azerbaijan@rsd.rohde-schwarz.com

Bangladesh BIL Consortium Ltd.
Corporate Office
House-33, Road-4, Block-F
Banani, Dhaka-1213

(Tel) +880 (2) 881 06 53
(Fax) +880 (2) 882 82 91

Barbados siehe / see Mexico

Belarus siehe/see Ukraine

Belgium Rohde & Schwarz Belgium N.V.
Excelsiorlaan 31 Bus 1
1930 Zaventem

(Tel) +32 (2) 721 50 02
(Fax) +32 (2) 725 09 36
info@rsb.rohde-schwarz.com

Belize siehe / see Mexico

Bermuda siehe/see Mexico

Bosnia-Herzegovina siehe/see Slovenia

Brazil Rohde & Schwarz Do Brasil Ltda.
Av. Alfredo Egidio de Souza Aranha (Rod. Araxá)
1° andar - Santo Amaro
04726-170 Sao Paulo - SP

(Tel) +55 (11) 56 44 86 11
(Fax) +55 (11) 56 44 86 25 (sales)
(Fax) +55 (11) 56 44 86 36
sales-brazil@rsdb.rohde-schwarz.com

Brunei George Keen Lee Equipment Pte Ltd.
#11-01 BP Tower
396 Alexandra Road
Singapore 119954

(Tel) +656 276 06 26
(Fax) +656 276 06 29
gkleqpt@singnet.com.sg

Bulgaria Rohde & Schwarz
Representation Office Bulgaria
39, Fridtjof Nansen Blvd.
1000 Sofia

(Tel) +359 (2) 96 343 34
(Fax) +359 (2) 963 21 97
rs-bulgaria@rsbg.rohde-schwarz

Canada Rohde & Schwarz Canada Inc.
555 March Rd.
Kanata, Ontario K2K 2M5

(Tel) +1 (613) 592 80 00
(Fax) +1 (613) 592 80 09
sales@rscanada.ca

Chile Dymeq Ltda.
Av. Larrain 6666
Santiago

(Tel) +56 (2) 339 20 00
(Fax) +56 (2) 339 20 10
dymeq@dymeq.com

China Rohde & Schwarz China Ltd.
Representative Office Beijing
6F, Parkview Center
2 Jiangtai Road
Chao Yang District
Beijing 100016

(Tel) +86 (10) 64 31 28 28
(Fax) +86 (10) 64 37 98 88
info.rschina@rsbp.rohde-schwarz.com

Rohde & Schwarz China Ltd.
Representative Office Shanghai
Room 807-809, Central Plaza
227 Huangpi North Road
Shanghai 200003

(Tel) +86 (21) 63 75 00 18
(Fax) +86 (21) 63 75 91 70
May.Zhu@rsbp.rohde-schwarz.com

Rohde & Schwarz China Ltd.
Representative Office Guangzhou
Room 2903, Metro Plaza
183 Tian He North Road
Guangzhou 510075

(Tel) +86 (20) 87 55 47 58
(Fax) +86 (20) 87 55 47 59
Winnie.Lin@rsbp.rohde-schwarz.com

Adressen/Addresses

China	Rohde & Schwarz China Ltd. Representative Office Chengdu Unit G, 28/F, First City Plaza 308 Shuncheng Avenue Chengdu 610017	(Tel) +86 (28) 86 52 76 06 (Fax) +86 (28) 86 52 76 10 sophia.chen@rsbp.rohde-schwarz.com	Germany	Zweigniederlassung Büro Bonn Josef-Wirmer-Straße 1-3 · D-53123 Bonn Postfach 140264 · D-53057 Bonn	(Tel) +49 (228) 918 90-0 (Fax) +49 (228) 25 50 87 info.rsv@rohde-schwarz.com
	Rohde & Schwarz China Ltd. Representative Office Xian Room 603, Jin Xin International No. 99 Heping Road Xian 710001	(Tel) +86 (29) 87 41 53 77 (Fax) +86 (29) 87 20 65 00 sherry.yu@rsbp.rohde-schwarz.com		Zweigniederlassung Nord, Geschäftsstelle Hamburg Vierenkamp 6 D-22423 Hamburg	(Tel) +49 (40) 38 61 83 - 00 (Fax) +49 (40) 38 61 83 - 20 info.rsv@rohde-schwarz.com
	Rohde & Schwarz China Ltd. Representative Office Shenzhen Room 1901, Central Business Building No. 88 Fuhua Yilu Futian District Shenzhen 518026	(Tel) +86 (755) 82 03 11 98 (Fax) +86 (755) 82 03 30 70 jessica.lia@rsbp.rohde-schwarz.com		Zweigniederlassung Mitte, Geschäftsstelle Köln Nieder Kasseler Straße 33 · D-51147 Köln Postfach 900 149 · D-51111 Köln	(Tel) +49 (2203) 807-0 (Fax) +49 (2203) 807-650 info.rsv@rohde-schwarz.com
Costa Rica	siehe / see Mexico			Zweigniederlassung Süd, Geschäftsstelle München Mühldorfstraße 15 · D-81671 München Postfach 80 14 69 · D-81614 München	(Tel) +49 (89) 41 86 95-0 (Fax) +49 (89) 40 47 64 info.rsv@rohde-schwarz.com
Croatia	siehe/see Slovenia			Zweigniederlassung Süd, Geschäftsstelle Nürnberg Donaustraße 36 D-90451 Nürnberg	(Tel) +49 (911) 642 03-0 (Fax) +49 (911) 642 03-33 info.rsv@rohde-schwarz.com
Cuba	siehe / see Mexico			Zweigniederlassung Mitte, Geschäftsstelle Neu-Isenburg Siemensstraße 20 D-63263 Neu-Isenburg Postfach 16 51 D-63236 Neu-Isenburg	(Tel) +49 (6102) 20 07-0 (Fax) +49 (6102) 20 07 12 info.rsv@rohde-schwarz.com
Cyprus	Hinis Telecast Ltd. Agiou Thoma 18 Kiti Larnaca 7550	(Tel) +357 (24) 42 51 78 (Fax) +357 (24) 42 46 21 hinis@logos.cy.net	Ghana	Kop Engineering Ltd. P.O. Box 11012 3rd Floor Akai House, Osu Accra North	(Tel) +233 (21) 77 89 13 (Fax) +233 (21) 701 06 20 joblink@ghana.com
Czech Republic	Rohde & Schwarz Praha, s.r.o. Hadovka Office Park Evropská 2590/33c 16000 Praha 6	(Tel) +420 (2) 24 31 12 32 (Fax) +420 (2) 24 31 70 43 office@rscb.rohde-schwarz.com	Greece	Mercury S.A. 6, Loukianou Str. 10675 Athens	(Tel) +302 (10) 722 92 13 (Fax) +302 (10) 721 51 98 mercury@hol.gr
Denmark	Rohde & Schwarz Danmark A/S Ejby Industrivej 40 2600 Glostrup	(Tel) +45 (43) 43 66 99 (Fax) +45 (43) 43 77 44 rsdk@rsdk.rohde-schwarz.com	Guatemala	siehe/see Mexico	
Egypt	U.A.S. Universal Advanced Systems 31 Manshiet El-Bakry Street Heliopolis 11341 Cairo	(Tel) +20 (2) 455 67 44 (Fax) +20 (2) 256 17 40 an_uas@link.net	Guiana	siehe / see Mexico	
El Salvador	siehe/see Mexico		Haiti	siehe / see Mexico	
Estonia	Rohde & Schwarz Danmark A/S Estonian Branch Office Narva mnt. 13 10151 Tallinn	(Tel) +372 (6) 14 31 23 (Fax) +372 (6) 14 31 21 estonia@rsdk.rohde-schwarz.com	Honduras	siehe/see Mexico	
Finland	Rohde & Schwarz Finland Oy Taivaltie 5 01610 Vantaa	(Tel) +358 (207) 60 04 00 (Fax) +358 (207) 60 04 17 info@rsfin.rohde-schwarz.com	Hong Kong	Electronic Scientific Engineering 9/F North Somerset House Taikoo Place 979 King's Road, Quarry Bay Hong Kong	(Tel) +852 (25) 07 03 33 (Fax) +852 (25) 07 09 25 stephenchau@ese.com.hk
France	Rohde & Schwarz France Immeuble "Le Newton" 9-11, rue Jeanne Braconnier 92366 Meudon La Forêt Cédex	(Tel) +33 (0) 141 36 10 00 (Fax) +33 (0) 141 36 11 11 contact@rsf.rohde-schwarz.com	Hungary	Rohde & Schwarz Budapesti Iroda Váci út 169 1138 Budapest	(Tel) +36 (1) 412 44 60 (Fax) +36 (1) 412 44 61 rs-hungary@rshu.rohde-schwarz.com
	Niederlassung/Subsidiary Rennes 37 Rue du Bignon Bâtiment A 35510 Cesson Sévigné	(Tel) +33 (2) 99 51 97 00 (Fax) +33 (2) 99 51 98 77	Iceland	siehe/see Denmark	
Germany	Zweigniederlassungen der Rohde & Schwarz Vertriebs-GmbH/Branch offices of Rohde & Schwarz Vertriebs-GmbH		India	Rohde & Schwarz India Pvt. Ltd. 244, Okhla Industrial Estate Phase - III New Delhi 110 020	(Tel) +91 (11) 26 32 63 81 (Fax) +91 (11) 26 32 63 73 sales@rsindia.rohde-schwarz.com
	Zweigniederlassung Nord, Geschäftsstelle Berlin Ernst-Reuter-Platz 10 · D-10587 Berlin Postfach 100620 · D-10566 Berlin	(Tel) +49 (30) 34 79 48-0 (Fax) +49 (30) 34 79 48 48 info.rsv@rohde-schwarz.com		Rohde & Schwarz India Pvt. Ltd. Bangalore Office No. 24, Service Road, Domlur 2nd Stage Extension Bangalore - 560 071	(Tel) +91 (80) 535 23 62 (Fax) +91 (80) 535 03 61 rsindiab@rsnl.net
				Rohde & Schwarz India Pvt. Ltd. Hyderabad Office 302 & 303, Millennium Centre 6-3-1099/1100, Somajiguda Hyderabad - 500 016	(Tel) +91 (40) 23 32 24 16 (Fax) +91 (40) 23 32 27 32 rsindiah@nd2.dot.net.in

Adressen/Addresses

India	Rohde & Schwarz India Pvt. Ltd. Mumbai Office B-603, Remi Bizcourt, Shah Industrial Estate, Off Veera Desai Road Andheri West Mumbai - 400 058	(Tel) +91 (22) 26 30 18 10 (Fax) +91 (22) 26 73 20 81 rsindiam@rsnl.net	Kazakhstan	Rohde & Schwarz Kazakhstan Representative Office Almaty Pl. Respubliki 15 480013 Almaty	(Tel) +7 (32) 72 67 23 54 (Fax) +7 (32) 72 67 23 46 rs-kazakhstan@rsd-rohde-schwarz.com
Indonesia	PT Rohde & Schwarz Indonesia Graha Paramita 5th Floor Jln. Denpasar Raya Blok D-2 Jakarta 12940	(Tel) +62 (21) 252 36 08 (Fax) +62 (21) 252 36 07 sales@rsbj.rohde-schwarz.com-services@rsbj.rohde-schwarz.com	Kenya	Excel Enterprises Ltd Dunga Road P.O.Box 42 788 Nairobi	(Tel) +254 (2) 55 80 88 (Fax) +254 (2) 54 46 79
Iran	Rohde & Schwarz Iran Liaison Office Tehran Groundfloor No. 1, 14th Street Khaled Eslamboli (Vozara) Ave. 15117 Tehran	(Tel) +98 (21) 872 42 96 (Fax) +98 (21) 871 90 12 alfred.korff@rsd.rohde-schwarz.com	Korea	Rohde & Schwarz Korea Ltd. 83-29 Nonhyun-Dong, Kangnam-Ku Seoul 135-010	(Tel) +82 (2) 34 85 19 00 (Fax) +82 (2) 547 43 00 sales@rskor.rohde-schwarz.com-service@rskor.rohde-schwarz.com
Ireland	siehe/see United Kingdom		Kuwait	Group Five Trading & Contracting Co. Mezzanine Floor Al-Bana Towers Ahmad Al Jaber Street Sharq	(Tel) +965 (244) 91 72/73/74 (Fax) +965 (244) 95 28 jk_agarwal@yahoo.com
Israel	Eastronics Ltd. Measurement Products 11 Rozanis St. P.O.Box 39300 Tel Aviv 61392	(Tel) +972 (3) 645 87 77 (Fax) +972 (3) 645 86 66 david_hasky@easx.co.il	Latvia	Rohde & Schwarz Danmark A/S Latvian Branch Office Merkela iela 21-301 1050 Riga	(Tel) +371 (7) 50 23 55 (Fax) +371 (7) 50 23 60 latvia@rsdk.rohde-schwarz.com
	J.M. Moss (Engineering) Ltd. Communications Products 9 Oded Street P.O.Box 967 52109 Ramat Gan	(Tel) +972 (3) 631 20 57 (Fax) +972 (3) 631 40 58 jmoss@zahav.net.il	Lebanon	Rohde & Schwarz Liaison Office Riyadh P.O.Box 361 Riyadh 11411	(Tel) +966 (1) 465 64 28 Ext. 303 (Fax) +966 (1) 465 64 28 Ext. 229 chris.porzky@rsd.rohde-schwarz.com
Italy	Rohde & Schwarz Italia S.p.a. Centro Direzionale Lombardo Via Roma 108 20060 Cassina de Pecchi (MI)	(Tel) +39 (02) 95 70 41 (Fax) +39 (02) 95 30 27 72 rsi.info@rsi.rohde-schwarz.com		Netcom P.O.Box 55199 Op. Ex-Presidential Palace Horch Tabet Beirut	(Tel) +961 (1) 48 69 99 (Fax) +961 (1) 49 05 11 tohme.sayar@netcomm.tv
	Rohde & Schwarz Italia S.p.a. Via Tiburtina 1182 00156 Roma	(Tel) +39 (06) 41 59 81 (Fax) +39 (06) 41 59 82 70 rsi.info@rsi.rohde-schwarz.com	Liechtenstein	siehe/see Switzerland	
Jamaica	siehe / see Mexico		Lithuania	Rohde & Schwarz Danmark A/S Lithuanian Branch Office Lukiskiu 5-228 2600 Vilnius	(Tel) +370 (5) 239 50 10 (Fax) +370 (5) 239 50 11 lithuania@rsdk.rohde-schwarz.com
Japan	Rohde & Schwarz Japan K.K. Tokyo Office 711 Bldg., Room 501 (5th floor) 7-11-18 Nishi-Shinjuku Shinjuku-ku Tokyo 160-0023	(Tel) +81 (3) 59 25 12 88 (Fax) +81 (3) 59 25 12 90 scj.support@rsjp.rohde-schwarz.com	Luxembourg	siehe/see Belgium	
	Rohde & Schwarz Japan K.K. Shin-Yokohama Office KM Daiichi Bldg., 8F 2-13-13 Kouhoku-ku Yokohama-shi Kanagawa 222-0033	(Tel) +81 (4) 54 77 35 70	Macedonia	NETRA Sarski odred 7 1000 Skopje	(Tel) +389 (2) 329 82 30 (Fax) +389 (2) 317 74 88 netra@netra.com.sk
	Rohde & Schwarz Japan K.K. Osaka Office TEK Dai 2 Bldg., 8F 1-13-20 Esaka-shi Suita-shi Osaka-fu 564-0063	(Tel) +81 (6) 63 10 96 51	Malaysia	Rohde & Schwarz Malaysia Sdn Bhd Suite 10.04, Level 10, Wisma E&C No. 2 Lorong Dungun Kiri Damansara Heights 50490 Kuala-Lumpur	(Tel) +60 (3) 20 94 00 33 (Fax) +60 (3) 20 94 24 33 sales.malaysia@rohde-schwarz.com
Jordan	Jordan Crown Engineering & Trading Co. Jabal Amman, Second Circle Youssef Ezzideen Street P.O.Box 830414 Amman, 11183	(Tel) +962 (6) 462 17 29 (Fax) +962 (6) 465 96 72 jocrown@go.com.jo	Malta	Tektraco International Technology Ltd. 121, B'Kara Road San Gwann SGN 08	(Tel) +356 (21) 37 43 00 or 37 80 88 (Fax) +356 (21) 37 66 67 sales@tektraco.com
			Mexico	Rohde & Schwarz de Mexico S. de R.L. de C.V. German Centre Oficina 4-2-2 Av. Santa Fé 170 Col. Lomas de Santa Fé 01210 Mexico D.F.	(Tel) +52 (55) 85 03 99 13 (Fax) +52 (55) 85 03 99 16 latinoamerica@rsd-rohde-schwarz.com
			Moldava	siehe/see Austria	
			Nepal	ICTC Pvt. Ltd. Hattisar, Post Box No. 660 Kathmandu	(Tel) +977 (1) 443 48 95 (Fax) +977 (1) 443 49 37 ictc@mos.com.np

Adressen/Addresses

Netherlands	Rohde & Schwarz Nederland B.V. Perkinsbaan 1 3439 ND Nieuwegein	(Tel) +31 (30) 600 17 00 (Fax) +31 (30) 600 17 99 info@rsn.rohde-schwarz.com	Saudi Arabia	Gentec Haji Abdullah Alireza & Co. Ltd. P.O.Box 43054 Riyadh	(Tel) +966 (1) 293 20 35 (Fax) +966 (1) 466 16 57 akanbar@gentec.com.sa
New Zealand	Nichecom 1 Lincoln Ave. Tawa, Wellington	(Tel) +64 (4) 232 32 33 (Fax) +64 (4) 232 32 30 rob@nichecom.co.nz	Serbia-Montenegro	Rohde & Schwarz Representative Office Belgrade Tose Jovanovica 7 11030 Beograd	(Tel) +381 (11) 305 50 25 (Fax) +381 (11) 305 50 24 rs-scg@rscs.rohde-schwarz.com
Nicaragua	siehe/see Mexico		Singapore	Rohde & Schwarz Regional Headquarters Singapore Pte. Ltd. 1 Kaki Bukit View #05-01/02 Techview Singapore 415 941	(Tel) +65 68 46 18 72 (Fax) +65 68 46 12 52
Nigeria	Ferrostaal Abuja Plot 3323, Barada Close P.O.Box 8513, Wuse Off Amazon Street Maitama, Abuja	(Tel) +234 (9) 413 52 51 (Fax) +234 (9) 413 52 50 fsabuja@rosecom.net		Rohde & Schwarz Systems & Communications Asia Pte Ltd Service 1 Kaki Bukit View #04-01/07 Techview Singapore 415 941	(Tel) +65 68 46 37 10 (Fax) +65 68 46 00 29 info@rssg.rohde-schwarz.com
Norway	Rohde & Schwarz Norge AS Enebakkeveien 302 B 1188 Oslo	(Tel) +47 (23) 38 66 00 (Fax) +47 (23) 38 66 01 firmapost@rsnor.rohde-schwarz.com	Slovak Republic	Specialne systémy a software, a.s. Svrčia ul. 3 841 04 Bratislava 4	(Tel) +421 (2) 65 42 24 88 (Fax) +421 (2) 65 42 07 68 3s@special.sk
Oman	Mustafa Sultan Science & Industry Co.LLC. Test & Measurement Products Way No. 3503 Building No. 241 Postal Code 112 Al Khuwair, Muscat	(Tel) +968 63 60 00 (Fax) +968 60 70 66 m-aziz@mustafasultan.com	Slovenia	Rohde & Schwarz Representative Office Ljubljana Tbilisjska 89 1000 Ljubljana	(Tel) +386 (1) 423 46 51 (Fax) +386 (1) 423 46 11 rs-slovenia@rssi.rohde-schwarz.com
Pakistan	Siemens Pakistan 23, West Jinnah Avenue Islamabad	(Tel) +92 (51) 227 22 00 (Fax) +92 (51) 227 54 98 reza.bokhary@siemens.com.pk	South Africa	Protea Data Systems (Pty.) Ltd. Communications and Measurement Division Private Bag X19 Bramley 2018	(Tel) +27 (11) 719 57 00 (Fax) +27 (11) 786 58 91 unicm@protea.co.za
Panama	siehe/see Mexico			Protea Data Systems (Pty.) Ltd. Cape Town Branch Unit G9, Centurion Business Park Bosmandam Road Milnerton Cape Town, 7441	(Tel) +27 (21) 555 36 32 (Fax) +27 (21) 555 42 67 unicm@protea.co.za
Papua New Guinea	siehe/see Australia		Spain	Rohde & Schwarz Espana S.A. Salcedo, 11 28034 Madrid	(Tel) +34 (91) 334 10 70 (Fax) +34 (91) 729 05 06 rses@rses.rohde-schwarz.com
Paraguay	siehe/see Argentina			Rohde & Schwarz Espana S.A. Av. Príncipe d'Astúries, 66 08012 Barcelona	(Tel) +34 (93) 415 15 68 (Fax) +34 (93) 237 49 95 bcn@rses.rohde-schwarz.com
Philippines	Rohde & Schwarz (Philippines) Inc. Unit 2301, PBCOM Tower 6795, Ayala Ave. cor. Herrera St. Makati City	(Tel) +63 (2) 753 14 44 (Fax) +63 (2) 753 14 56	Sri Lanka	Dynatel Communications (PTE) Ltd. 451/A Kandy Road Kelaniya	(Tel) +94 (112) 90 80 01 (Fax) +94 (112) 91 04 69 69 dynatel@dyanet.lk
Poland	Rohde & Schwarz SP.z o.o. Przedstawicielstwo w Polsce ul. Stawki 2, Pietro 28 00-193 Warszawa	(Tel) +48 (22) 860 64 94 (Fax) +48 (22) 860 64 99 rs-poland@rspl.rohde-schwarz.com	Sudan	SolarMan Co. Ltd. P.O.Box 11 545 North of Fraouq Cementry 6/7/9 Bldg. 16 Karthoum	(Tel) +249 (183) 47 31 08 (Fax) +249 (183) 47 31 38 solarman29@hotmail.com
Portugal	Rohde & Schwarz Portugal, Lda. Alameda Antonio Sergio 7-R/C - Sala A 2795-023 Linda-a-Velha	(Tel) +351 (21) 415 57 00 (Fax) +351 (21) 415 57 10 info@rspt.rohde-schwarz.com	Sweden	Rohde & Schwarz Sverige AB Flygfältsgatan 15 128 30 Skarpnäck	(Tel) +46 (8) 605 19 00 (Fax) +46 (8) 605 19 80 info@rss.rohde-schwarz.com
Republic Dominican	siehe/see Mexico		Switzerland	Roschi Rohde & Schwarz AG Mühlestr. 7 3063 Ittigen	(Tel) +41 (31) 922 15 22 (Fax) +41 (31) 921 81 01 support@roschi.rohde-schwarz.com
Romania	Rohde & Schwarz Representation Office Bucharest 89 Eroii Sanitari Blvd., sector 5 050472 Bucuresti	(Tel) +40 (21) 411 20 13 (Fax) +40 (21) 410 68 46 rs-romania@rsro.rohde-schwarz.com	Syria	Electro Scientific Office Baghdad Street Dawara Clinical Lab. Bldg P.O.Box 8162 Damascus	(Tel) +963 (11) 231 59 74 (Fax) +963 (11) 231 88 75 memo@hamshointl.com
Russian Federation	Rohde & Schwarz International GmbH 119180, Yakimanskaya nab., 2 Moscow	(Tel) +7 (095) 745 88 50 to 53 (Fax) +7 (095) 745 88 54 rs-russia@rsru.rohde-schwarz.com			
Saudi Arabia	Rohde & Schwarz International GmbH - Liaison Office Riyadh c/o Haji Abdullah Alireza Co. Ltd. P.O.Box 361 Riyadh 11411	(Tel) +966 (1) 293 2035 (Fax) +966 (1) 466 1657 chris.porzky@rsd.rohde-schwarz.com			

Adressen/Addresses

Taiwan	Rohde & Schwarz Taiwan (Pvt.) Ltd. Floor 14, No. 13, Sec. 2, Pei-Tou Road Taipei 112	(Tel) +886 (2) 28 93 10 88 (Fax) +886 (2) 28 91 72 60 celine.tu@rstw.rohde-schwarz.com	United Kingdom	Rohde & Schwarz UK Ltd. 3000 Manchester Business Park Aviator Way Manchester M22 5TG	(Tel) +44 (870) 735 16 42 (Fax) +44 (1252) 81 14 77 sales@rsuk.rohde-schwarz.com
Tanzania	SSTL Group P.O. Box 7512 Dunga Street Plot 343/345 Dar Es Salaam	(Tel) +255 (22) 276 00 37 (Fax) +255 (22) 276 02 93 sstl@ud.co.tz	Uruguay	Aeromarine S.A. Cerro Largo 1497 11200 Montevideo	(Tel) +598 (2) 400 39 62 (Fax) +598 (2) 401 85 97 cs@aeromarine.com.uy
Thailand	Rohde & Schwarz International Thailand 2nd floor Gems Tower Bangrak, Suriyawong Bangkok 10600	(Tel) +66 (2) 200 07 29 (Fax) +66 (2) 267 00 79	USA	Rohde & Schwarz, Inc. Eastern Regional Office (US Headquarters) 8661A Robert Fulton Drive Columbia, MD 21046-2265	(Tel) +1 (410) 910 78 00 (Fax) +1 (410) 910 78 01 info@rsa.rohde-schwarz.com
	Schmidt Electronics (Thailand) Ltd. Messtechnik 202 Le Concorede Tower, 23rd Fl. Ratchadaphisek Rd. Huay kwang Bangkok 10320	(Tel) +66 (2) 69 41 47 05 (Fax) +66 (2) 69 41 47 06 salestm@schmidtelectronics.com		Rohde & Schwarz, Inc. Central Regional Office / Systems & EMI Products 8080 Tristar Drive Suite 120 Irving, TX 75063	(Tel) +1 (469) 713 53 00 (Fax) +1 (469) 713 53 01 info@rsa.rohde-schwarz.com
	TPP Operation Co. Ltd. Kommunikationstechnik 41/5 Mooban Tarinee Boromrajchonnee Road Talingchan Bangkok 10170	(Tel) +66 (2) 880 93 47 (Fax) +66 (2) 880 93 47		Rohde & Schwarz, Inc. R&D and Application Support 8905 SW Nimbus Ave Suite 240 Beaverton, OR 97008	(Tel) +1 (503) 403 47 00 (Fax) +1 (503) 403 47 01 info@rsa.rohde-schwarz.com
Trinidad & Tobago	siehe/see Mexico	(Tel) (Fax)		Rohde & Schwarz, Inc. Western Regional Office 7700 Irvine Center Drive Suite 100 Irvine, CA 92618	(Tel) +1 (949) 885 70 00 (Fax) +1 (949) 885 70 01 info@rsa.rohde-schwarz.com
Tunisia	Teletek 71, Rue Alain Savary Residence Alain Savary (C64) Cit� el Khadra 1003 Tunis	(Tel) +216 (71) 77 33 88 (Fax) +216 (71) 77 05 53 teletek@gnet.tn		Rohde & Schwarz, Inc. Service & Calibration Center 8661A Robert Fulton Drive Columbia, MD 21046-2265	(Tel) +1 (410) 910 50 02 (Fax) +1 (410) 910 79 31 service.rsa@rsa.rohde-schwarz.com
Turkey	Rohde & Schwarz International GmbH Liaison Office Istanbul Bagdat Cad. 191/3, Arda Apt. B-Blok 81030 Selamicesme-Istanbul	(Tel) +90 (216) 385 19 17 (Fax) +90 (216) 385 19 18 nadir.guerelman@rsd.rohde-schwarz.com	Vietnam	Rohde & Schwarz Representative Office Vietnam Unit 807, 8/F, Schmidt Tower 239 Xuan Thuy Road Cau Giay District Hanoi	(Tel) +84 (4) 834 20 46
Ukraine	Rohde & Schwarz Representative Office Kiev 4, Patris Loumoumba ul. 01042 Kiev	(Tel) +38 (044) 268 60 55 (Fax) +38 (044) 268 83 64 rsbkiev@public.ua.net	West Indies	siehe/see Mexico	
United Arab Emirates	Rohde & Schwarz International GmbH Liaison Office Middle East Vertrieb P.O. Box 31156 Abu Dhabi	(Tel) +971 (2) 6335 670 (Fax) +971 (2) 6335 671 Dario Barisoni@rsd.rohde-schwarz.com			
	Rohde & Schwarz Bick Mobile Communication P.O.Box 17466 JAFZ, PPU ZG-07 Dubai	(Tel) +971 (4) 883 71 35 (Fax) +971 (4) 883 71 36			
	Rohde & Schwarz Emirates L.L.C. ESNAAD Premisses at Mussafah, P.O.Box 31156 Abu Dhabi	(Tel) +971 (2) 55 49 411 (Fax) +971 (2) 55 49 433 rsuaeam@emirates.net.ae			
United Kingdom	Rohde & Schwarz UK Ltd. Ancells Business Park Fleet Hampshire GU51 2UZ	(Tel) +44 (1252) 81 88 88 (sales)+44 (1252) 81 88 18 (service) (Fax) +44 (1252) 81 14 47 sales@rsuk.rohde-schwarz.com			

Contents of Manual for Spectrum Analyzer R&S FSH

Service Manual - Instrument

The Service Manual - Instrument describes how to check compliance with rated specifications, as well as instrument function, repair, troubleshooting and fault elimination. It contains all information required when repairing the R&S FSH by replacing modules.

This Service Manual consists of four chapters and an annex (chapter 5) that describes how to ship the instrument and to order spare parts.

- | | |
|------------------|---|
| Chapter 1 | provides all the information necessary to check for compliance with rated specifications. The required test equipment is also specified. |
| Chapter 2 | describes the manual adjustment of the calibration source and of the frequency accuracy as well as the automatic adjustment of individual module data following module replacement. |
| Chapter 3 | describes the design as well as simple measures for repair and fault diagnosis, including in particular the replacement of modules. |
| Chapter 4 | contains information about extensions and modifications by installing instrument software and retrofitting options. |
| Chapter 5 | describes how to ship the instrument and order spare parts, and contains spare parts lists. |

Operating Manual

The Operating Manual provides information about the technical specifications, the controls and connectors on the front and rear panel, required steps for placing the instrument into operation, the basic operating concept, as well as manual and remote control.

Typical measurement tasks are explained in detail using the functions of the user interface and program examples.

The Operating Manual also provides useful information on preventive maintenance and fault diagnosis by means of warnings and error messages output by the unit.

Quick Start Manual

The Quick Start Manual provides information about typical measurement tasks, the basic operation concept, as well as manual and remote control. Each of these items is explained in detail using the functions of the user interface and program examples.

Service and Repair

If your equipment requires service or repair or if you want to order spare parts and modules, please contact your Rohde & Schwarz support center or our spare parts express service.

Rohde & Schwarz representatives and the address of our spare parts express service are listed in the front section of this service manual.

You will need to provide the following information in order for us to respond to your inquiries quickly and accurately and to determine whether the warranty for your instrument is still valid:

- Instrument model
- Serial number
- Firmware version
- Detailed error description in case of repair
- Contact partner for checkbacks

Rohde & Schwarz offers the following calibrations:

- Calibration on R&S-type test systems. The calibration documentation meets the requirements of the quality management system ISO 9000.
- Calibration at an R&S calibration center approved by the German Calibration Service (DKD). The calibration documentation consists of the DKD calibration certificate.

Refer to Chapter 5 for a detailed description of how to ship the instrument and to order spare parts.

1 Performance Test

Test Instructions

- The rated specifications of the analyzer are tested after a warm-up time of at least 15 minutes. Only by adhering to this requirement can compliance with the guaranteed data be ensured.
- Values specified in the following sections are not guaranteed. Only the technical specifications provided on the data sheet are binding.
- The values specified in the data sheet are the guaranteed limits.
- Inputs for settings during measurements are shown as following:
 - [<KEY>] Press a key on the front panel, eg [**SPAN**]
 - [<SOFTKEY>] Press a softkey, e.g. [**MARKER -> PEAK**].
 - [<nn unit>] Enter a value and terminate by entering the unit, e.g. [**12 kHz**].
 Successive entries are separated by [:], e.g. [**BW : MANUAL RES BW : 3 kHz**].

Measuring Equipment and Accessories

Item	Type of equipment	Specifications recommended	Equipment recommended	R&S order no.	Use
1	Signal generator	Frequency: R&S [®] FSH3 10 MHz to 3 GHz R&S [®] FSH6 10 MHz to 6 GHz Uncertainty of frequency: 0.1 ppm Phase noise at 500 MHz: < -100 dBc (1Hz) @ 10 kHz < -110 dBc (1Hz) @ 100 kHz < -130 dBc (1Hz) @ 1 MHz	R&S SML03 R&S SMT06	1090.3000.13 1039.2000.06	Frequency response Frequency accuracy of reference oscillator
2	6-dB divider (power splitter)		Weinschel 1870A		Frequency response
3	Power meter		R&S NRP	1143.8500.02	Frequency response
4	Power sensor	1 MHz to 6 GHz RSS ≤ 0.8% Meter noise ≤ 20 pW	R&S NRP-Z91	1168.8004.02	Frequency response
5	N cable	Attenuation < 1 dB to 6 GHz			Tracking generator output level
6	50-Ω termination	1 MHz to 6 GHz Return loss ≤ -10 dB			Noise display

Performance Test

Checking the frequency accuracy

- Test equipment: Signal generator (refer to section "Measurement Equipment and Accessories", item 1)
- Test setup: ➤ Connect the signal generator to the RF input of the R&S FSH.
- Signal generator settings:
- Frequency 1 GHz
 - Level -30 dBm
- R&S FSH settings:
- [**PRESET**]
 - [**FREQ : 1 GHz**]
 - [**SPAN : 100 kHz**]
 - [**BW : MANUAL RES BW : 10 kHz**]
 - [**MARKER : MARKER MODE : FREQ COUNT**]
- Measurement: ➤ Read out the frequency value (Count:) of the marker.
- Nominal frequency: 1.0 GHz ± 1 kHz
- Note:** *The frequency of the reference oscillator can be adjusted by means of a service function (refer to Chapter 2 "Adjustment").*

Checking the level accuracy and the frequency response

- Test equipment:
- Signal generator (refer to section "Measurement Equipment and Accessories", item 1)
 - Power meter (refer to section "Measurement Equipment and Accessories", item 3)
 - Power sensor (refer to section "Measurement Equipment and Accessories", item 4)
 - 6-dB power splitter (refer to section "Measurement Equipment and Accessories", item 2)

Determining the level accuracy at 100 MHz

- Test setup:
- Connect the power sensor (item 4) to the power meter and execute function 'ZERO' when there is no signal applied to the power sensor.
 - Connect the RF output of the signal generator to the input of the divider.
 - Connect output 1 of the divider to the power sensor / power meter.
 - Connect output 2 of the divider to the RF input of the R&S FSH.

- Signal generator settings:
- Frequency 100 MHz
 - Level 6 dBm
- Determine the output power of the signal generator with the power meter. Adjust the output power of the generator until the power meter shows 0 dBm.

- R&S FSH settings:
- [**PRESET**]
 - [**FREQ : 100 MHz**]
 - [**AMPT: 0 dBm**]
 - [**SPAN : 100 kHz**]
 - [**BW : MANUAL RES BW : 10 kHz**]
 - [**TRACE : DETECTOR : RMS**]
- Set the marker to the peak of the signal.
 - [**MARKER: SET MARKER: PEAK**]

Evaluation: The difference between the signal levels measured with the power meter and the level reading of the marker reflects the absolute level error of the R&S FSH. It can be calculated as:

$$\text{Level error}_{100\text{ MHz}} = L - L_{\text{powermeter}}$$

Checking the frequency response

For the measurement of the frequency response, the value at 100 MHz for each reference level setting is used as the reference. The reference level influences the RF attenuation (RF attenuation = +10 dBm + reference level).

- Test setup:
- Connect the RF output of the signal generator to the input of the divider.
 - Connect output 1 of the divider to the power sensor / power meter.
 - Connect output 2 of the divider to the RF input of the SA..

- Signal generator settings:
- Frequency $\{f_{in}\}^*$
 - Level -4 dBm

Determine the output power of the signal generator with the power meter. Adjust the output power of the generator until the power meter shows -10 dBm.

- R&S FSH settings:
- [**PRESET**]
 - [**AMPT** : Ref_Lev*)]
 - [**SPAN** : 100 kHz]
 - [**BW** : MANUAL RES BW : 10 kHz]
 - [**TRACE** : DETECTOR : RMS]
 - [**FREQ** : CENTER : $\{f_{in}\}^*$]
 - [**SETUP** : Hardware Setup: Low Noise]

*) Refer to table under “Performance Test Report” for values of Ref_Lev and f_{in} .

If the a RF preamplifier is installed, its frequency response has to be checked also. To switch it on please enter:

- Reference measurement:
- [**SETUP** : Hardware Setup: Preamp: ON]
 - Determine signal level $L_{\text{powermeter}}$.
 - Set the marker to the peak of the signal.
 - [**MARKER**: SET MARKER: PEAK]

The signal level L is displayed by the level reading of the marker.

$$\text{Ref}_{100\text{MHz}} = L - L_{\text{powermeter}}$$

Measurement

- Signal generator settings:
- Frequency $\{f_{in}\}$
- Refer to table under “Performance Test Report” for values of $\{f_{in}\}$.

- Power meter settings:
- Determine the signal level $L_{\text{powermeter}}$. To achieve higher accuracy, compensating the frequency response of the power sensor is recommended.

- R&S FSH settings:
- [**FREQ** : $\{f_{in}\}$]

Refer to table under “Performance Test Report” for values of $\{f_{in}\}$.

- Set the marker to the peak of the signal.

- [**MARKER**: SET MARKER: PEAK]

The signal level L is displayed by the level reading of the marker.

Evaluation:

The frequency response can be calculated as:

$$\text{Frequency response} = L - L_{\text{powermeter}} - \text{Ref}_{100\text{ MHz}}$$

Checking the accuracy of the RF attenuator

- Test principle: The RF attenuator of the R&S FSH can be switched from 0 to 30 dB in 10-dB increments by changing the reference level (RF attenuation = +10 dBm + reference level).
- Test equipment:
- Signal generator (refer to section "Measurement Equipment and Accessories", item 3)

Frequency	100 MHz
Maximum level	≥ 6 dBm
- Test setup:
- Connect the RF output of the signal generator to the input of the divider.
 - Connect output 1 of the divider to the power sensor / power meter.
 - Connect output 2 of the divider to the RF input of the R&S FSH.
- Signal generator settings:
- Frequency 100 MHz
 - Level -14 dBm
 - Determine the output power of the signal generator with the power meter. Adjust the output power of the signal generator until the power meter shows -20 dBm ± 0.2 dB.
- R&S FSH settings:
- [**PRESET**]
 - [**FREQ : 100 MHz**]
 - [**SPAN : 10 kHz**]
 - [**BW : MANUAL RES BW : 1 kHz**]
 - [**BW : MANUAL VIDEO BW : 100 Hz**]
 - [**TRACE : DETECTOR : RMS**]
 - [**AMPT : 0 dBm**]
 - [**SETUP : Hardware Setup: Low Noise**]
- Reference measurement:
- Set the marker to the peak of the signal.
[**MARKER: SET MARKER: PEAK**]

The signal level L is displayed by the level reading of the marker.

$$\text{Ref}_{0\text{dBm}} = L - L_{\text{powermeter}}$$

Measurement

- Signal generator settings:
- Frequency 100 MHz
 - Level Ref_Lev *) – 14 dB
- *) Refer to table under "Performance Test Report" for values of {Ref_Lev}.
- Determine the output power of the signal generator with the power meter. Adjust the output power of the generator until the power meter shows the value Ref_Lev – 10 dB.
- R&S FSH settings:
- [**AMPT : {Ref_Lev}**]
 - [**MARKER: SET MARKER: PEAK**]

- Evaluation:
- The signal level L is displayed by the level reading of the marker.
- The difference between the level inaccuracy of the R&S FSH and $\text{Ref}_{0\text{dBm}}$ (at 10 dB RF-Att) is the uncertainty of the RF attenuation:

$$\text{IF-Gain}_{\text{accuracy}} = (L - L_{\text{powermeter}}) - \text{Ref}_{0\text{dBm}}$$

Checking the accuracy of the IF gain setting

Test principle: The IF gain of the R&S FSH can be switched from 0 to 15 dB by changing the reference level.

Test equipment:

- Signal generator (refer to section "Measurement Equipment and Accessories", item 3)

Frequency	100 MHz
Maximum level	≥ -10 dBm

Test setup:

- Connect the RF output of the signal generator to the input of the divider.
- Connect output 1 of the divider to the power sensor / power meter.
- Connect output 2 of the divider to the RF input of the SA.

Signal generator settings:

- Frequency 100 MHz
- Level -4 dBm

➤ Determine the output power of the signal generator with the power meter. Adjust the output power of the generator until the power meter shows $-10 \text{ dBm} \pm 0.2 \text{ dB}$.

R&S FSH settings:

- [**PRESET**]
- [**FREQ: 100 MHz**]
- [**SPAN : 10 kHz**]
- [**BW : MANUAL RES BW: 1 kHz**]
- [**BW : MANUAL VIDEO BW : 100 Hz**]
- [**TRACE : DETECTOR : RMS**]
- [**AMPT : Ref_Lev ***]

*) Refer to table under "Performance Test Report" for values of {Ref_Lev}.

Reference measurement:

- Set the marker to the peak of the signal.
- [**MARKER: SET MARKER: PEAK**]

The signal level L is displayed by the level reading of the marker.

$$\text{Ref}_{-10\text{dBm}} = L - L_{\text{powermeter}}$$

Measurement

Signal generator settings:

- Frequency 100 MHz
- Level Ref_Lev + 6 dB

➤ Determine the output power of the signal generator with the power meter. Adjust the output power of the generator until the power meter shows the value $\text{Ref_Lev} \pm 0.2 \text{ dB}$.

R&S FSH settings:

- [**AMPT : {Ref_Lev}**]
- *) Refer to table under "Performance Test Report" for values of Ref_Lev.
- [**MARKER: SET MARKER: PEAK**]

Evaluation:

The signal level L is displayed by the level reading of the marker.
The difference between the level inaccuracy of the R&S FSH and $\text{Ref}_{-10\text{dBm}}$ (at 0 dB IF gain) is the uncertainty of the IF gain:

$$\text{IF-Gain}_{\text{accuracy}} = (L - L_{\text{powermeter}}) - \text{Ref}_{-10\text{dBm}}$$

Checking the displayed average noise floor

Test equipment:	50- Ω termination (refer to section "Measurement Equipment and Accessories", item 6)
Test setup:	➤ Terminate the RF input of the R&S FSH with 50 Ω .
R&S FSH settings:	<ul style="list-style-type: none">- [PRESET]- [SPAN : ZERO SPAN]- [Manual Res BW : 1 kHz]- [Manual Video BW : 10 Hz]- [TRACE : TRACE MODE: AVERAGE]- [AMPT : -30 dBm]- [FREQ : {f_n}] Refer to table under "Performance Test Report" for values of f_n .
Measurement:	➤ Read out the marker level.
Evaluation:	The displayed average noise floor is displayed by the level reading of the marker.

Checking the phase noise

Test equipment: Signal generator (refer to section "Measurement Equipment and Accessories", item 3)

Frequency	500 MHz
Level	0 dBm
Phase noise at 500 MHz:	< -100 dBc (1Hz) @ 10 kHz
	< -110 dBc (1Hz) @ 100 kHz
	< -120 dBc (1Hz) @ 1 MHz

Test setup: ➤ Connect the RF output of the signal generator to the RF input of the R&S FSH.

Signal generator settings:

- Frequency 500 MHz
- Level 0 dBm

R&S FSH settings:

- [PRESET]
- [**FREQ : 500 MHz**]
- [**AMPT : 0 dBm**]
- [**SPAN : 10 kHz**]
- [**BW : RBW MANUAL : 1 kHz**]
- [**TRACE : TRACE MODE: AVERAGE**]
- Set marker to peak :
[**MARKER: SET MARKER: PEAK**]
- Set marker mode to noise measurement
[**MARKER: MARKER MODE: NOISE**]

Depending on the offset, refer to the table below for values of center frequency, resolution bandwidth and reference level.

- [**FREQ** : {Center}]
- [**AMPT** : {Ampt}]]
- [**BW** : RBW MANUAL : {RBW}]
- [**MARKER: DELTA**: {offset}]

Evaluation: The phase noise is displayed in the marker field by the reading 'D: {offset} -xxx.x dBc/Hz'

Phase noise measurement settings				
Offset	Center Frequency	RBW	Reference Level	a _{R&S-FSH} (for information)
30 kHz	500.03 MHz	1 kHz	0 dBm	20 dB
100 kHz	500.1 MHz	10 kHz	0 dBm	20 dB
1 MHz	501 MHz	100 kHz	-20 dBm	0 dB

Note: To obtain a precise measurement of the phase noise at high offsets the level used at the R&S[®]FSH input is up to 20 dB higher than the reference level. To reduce the measurement time the phase noise is measured with a small span around the frequency offset. This prevents the R&S[®]FSH from being overloaded.

Checking the display linearity

- Test equipment:
- Signal generator (refer to section "Measurement Equipment and Accessories", item 1)
 - Power meter (refer to section "Measurement Equipment and Accessories", item 3)
 - Power sensor (refer to section "Measurement Equipment and Accessories", item 4)
 - 6-dB power splitter (refer to section "Measurement Equipment and Accessories", item 2)

- Test setup:
- Connect the power sensor (item 4) to the power meter and execute function 'ZERO' when there is no signal applied to the power sensor.
 - Connect the RF output of the signal generator to the input of the divider.
 - Connect output 1 of the divider to the power sensor / power meter.
 - Connect output 2 of the divider to the RF input of the R&S FSH.

1st Measurement

0 to 30 dB below reference level

- Signal generator settings:
- Frequency 100 MHz
 - Level + 6 dBm
- Determine the output power of the signal generator with the power meter. Adjust the output power of the generator until the power meter shows 0 dBm.

- R&S FSH settings:
- [**PRESET**]
 - [**AMPT: 0 dBm**]
 - [**FREQ: 100 MHz**]
 - [**SPAN : 10 kHz**]
 - [**Manual Res BW : 1 kHz**]
 - [**Manual SWPTime : 1 s**]
 - [**TRACE : DETECTOR : RMS**]

- Reference measurement:
- Set the marker to the peak of the signal.
 - [**MARKER: SET MARKER: PEAK**]

The signal level L is displayed by the level reading of the marker.

$$\text{Ref}_{0\text{dBm}} = L - L_{\text{powermeter}}$$

- Signal generator settings:
- Frequency 100 MHz
 - Level Sig_Lev + 6 dB

Refer to table under "Performance Test Report" for values of {Sig_Lev}.

- Determine the output power of the signal generator with the power meter. Adjust the output power of the generator until the power meter shows the value of {Sig_Lev}.

Evaluation: The signal level L is displayed by the level reading of the marker.
 The difference between the level inaccuracy of the R&S FSH and Ref_{0dBm} is the uncertainty of the display linearity:

$$Linearity_{uncertainty} = (L - L_{powermeter}) - Ref_{0dBm}$$

2nd Measurement
 30 to 50 dB below reference level

Because the sensitivity of the power meter is limited, the internal RF attenuator of the Galaxy is used to increase the dynamic range of the input signal.

R&S FSH settings: - [**AMPT: 20 dBm**]

Signal generator settings: - Frequency 100 MHz
 - Level - 4 dBm

- Determine the output power of the signal generator with the power meter. Adjust the output power of the generator until the power meter shows -10 dBm.

Reference measurement: ➤ Set the marker to the peak of the signal.
 - [**MARKER: SET MARKER: PEAK**]

The signal level L is displayed by the level reading of the marker.
 With the result of the 1st linearity measurement, a new correction factor is to be calculated. “Linearity_{uncertainty} (-30dB)” is the measured uncertainty of the R&S FSH linearity at 30 dB below reference level.

$$Ref_{20dBm} = (L - L_{powermeter}) - Linearity_{uncertainty} (-30dB)$$

Signal generator settings: - Frequency 100 MHz
 - Level Sig_Lev + 6 dB

Refer to table under “Performance Test Report” for values of {Sig_Lev}.

- Determine the output power of the signal generator with the power meter. Adjust the output power of the generator until the power meter shows the value Sig_Lev ± 0.2 dB.

Evaluation: The signal level L is displayed by the level reading of the marker.
 The difference between the level inaccuracy of the R&S FSH and Ref_{20dBm} is the uncertainty of the display linearity:

$$Linearity_{uncertainty} = (L - L_{powermeter}) - Ref_{20dBm}$$

Performance Test Tracking Generator

(Model 1145.5973.13, 1145.5973.23 or 1145.5973.26 only)

Checking output level / frequency response

Test equipment:

- N cable (refer to section "Measurement Equipment and Accessories", item 5)
- Frequency up to 3 GHz
- Maximum attenuation < 0.2 dB

Test setup: ➤ Connect the tracking generator output to the RF input of the R&S FSH.

R&S FSH settings:

- [**PRESET**]
- [**MEAS: TRACKING GENERATOR**]
- [**AMPT : REF: 10 dB**]
- [**FREQ : START FREQ 10 MHz**]

In the model 1145.5973.23 the output level of the tracking generator can be set to 0 dBm. Check the output level also with this setting:

- [**PRESET**]
- [**MEAS: TRACKING GENERATOR**]
- [**Output Level : 0 dBm**]
- [**AMPT : REF: 10 dB**]

In the FSH6 the output level of the tracking generator is measured with two different frequency settings :

1)

- [**FREQ : START FREQ 10 MHz**]
- [**FREQ : STOP FREQ 3 GHz**]

2)

- [**FREQ : START FREQ 3 GHz**]
- [**FREQ : STOP FREQ 6 GHz**]

Measurement: Tune the marker to the maximum level of the trace.

- [**MARKER: <tune the marker>**]

Read out the marker level.

Tune the marker to the minimum value of the trace.

Read out the marker level.

Performance Test Report

Table 1-1 Performance Test Report

ROHDE & SCHWARZ	Performance Test Report	Spectrum Analyzer	Version 11 - November 2005
Model (): Order number: Serial number: Test person: Date: Sign:			

Characteristic	Included in	Min. value	Actual value	Max. value	Unit	Measurement uncertainty
Frequency accuracy Reference oscillator	Page 1.2	0.999998	_____	1.000002	GHz	
Level accuracy at 100 MHz with Ref_Lev = 0 dBm	Page 1.3	-0.5	_____	+0.5	dB	

Characteristic	Included in	Min. value	Actual value	Max. value	Unit	Measurement uncertainty
Frequency response with Ref_Lev = 20 dBm	Page 1.3					
f_{resp}						
10 MHz		-1	_____	+1	dB	
100 MHz			Reference		dB	
500 MHz		-1	_____	+1	dB	
1000 MHz		-1	_____	+1	dB	
1500 MHz		-1	_____	+1	dB	
2000 MHz		-1	_____	+1	dB	
2500 MHz		-1	_____	+1	dB	
2990 MHz		-1	_____	+1	dB	
R&S°FSH6 only :						
3500 MHz		-1.2	_____	+1.2	dB	
4000 MHz		-1.2	_____	+1.2	dB	
4500 MHz		-1.2	_____	+1.2	dB	
5000 MHz		-1.2	_____	+1.2	dB	
5500 MHz		-1.2	_____	+1.2	dB	
5990 MHz		-1.2	_____	+1.2	dB	
Frequency response with Ref_Lev = 10 dBm	Page 1.3					
f_{resp}						
10 MHz		-1	_____	+1	dB	
100 MHz			Reference		dB	
500 MHz		-1	_____	+1	dB	
1000 MHz		-1	_____	+1	dB	
1500 MHz		-1	_____	+1	dB	
2000 MHz		-1	_____	+1	dB	
2500 MHz		-1	_____	+1	dB	
2990 MHz		-1	_____	+1	dB	
R&S°FSH6 only :						
3500 MHz		-1.2	_____	+1.2	dB	
4000 MHz		-1.2	_____	+1.2	dB	
4500 MHz		-1.2	_____	+1.2	dB	
5000 MHz		-1.2	_____	+1.2	dB	
5500 MHz		-1.2	_____	+1.2	dB	
5990 MHz		-1.2	_____	+1.2	dB	

Characteristic	Included in	Min. value	Actual value	Max. value	Unit	Measurement uncertainty
Frequency response with Ref_Lev = 0 dBm	Page 1.3					
f_{resp}						
10 MHz		-1	_____	+1	dB	
100 MHz			Reference		dB	
500 MHz		-1	_____	+1	dB	
1000 MHz		-1	_____	+1	dB	
1500 MHz		-1	_____	+1	dB	
2000 MHz		-1	_____	+1	dB	
2500 MHz		-1	_____	+1	dB	
2990 MHz		-1	_____	+1	dB	
R&S°FSH6 only :						
3500 MHz		-1.2	_____	+1.2	dB	
4000 MHz		-1.2	_____	+1.2	dB	
4500 MHz		-1.2	_____	+1.2	dB	
5000 MHz		-1.2	_____	+1.2	dB	
5500 MHz		-1.2	_____	+1.2	dB	
5990 MHz		-1.2	_____	+1.2	dB	
Frequency response with Ref_Lev = -10 dBm	Page 1.3					
f_{resp}						
10 MHz		-1	_____	+1	dB	
100 MHz			Reference		dB	
500 MHz		-1	_____	+1	dB	
1000 MHz		-1	_____	+1	dB	
1500 MHz		-1	_____	+1	dB	
2000 MHz		-1	_____	+1	dB	
2500 MHz		-1	_____	+1	dB	
2990 MHz		-1	_____	+1	dB	
R&S°FSH6 only :						
3500 MHz		-1.2	_____	+1.2	dB	
4000 MHz		-1.2	_____	+1.2	dB	
4500 MHz		-1.2	_____	+1.2	dB	
5000 MHz		-1.2	_____	+1.2	dB	
5500 MHz		-1.2	_____	+1.2	dB	
5990 MHz		-1.2	_____	+1.2	dB	

Characteristic	Included in	Min. value	Actual value	Max. value	Unit	Measurement uncertainty
Frequency response with PreAmp = ON (only if PreAmp is implemented) Ref_Lev = -15 dBm f_{fresp} 10 MHz 100 MHz 500 MHz 1000 MHz 1500 MHz 2000 MHz 2500 MHz 2990 MHz R&S°FSH6 only : 3500 MHz 4000 MHz 4500 MHz 5000 MHz 5500 MHz 5990 MHz	Page 1.3	-1	_____	+1	dB	
			Reference		dB	
		-1	_____	+1	dB	
		-1	_____	+1	dB	
		-1	_____	+1	dB	
		-1	_____	+1	dB	
		-1	_____	+1	dB	
		-1	_____	+1	dB	
		-1.2	_____	+1.2	dB	
		-1.2	_____	+1.2	dB	
		-1.2	_____	+1.2	dB	
		-1.2	_____	+1.2	dB	
		-1.2	_____	+1.2	dB	
		-1.2	_____	+1.2	dB	
Frequency response with PreAmp = ON (only if PreAmp is implemented) Ref_Lev = -25 dBm f_{fresp} 10 MHz 100 MHz 500 MHz 1000 MHz 1500 MHz 2000 MHz 2500 MHz 2990 MHz R&S°FSH6 only : 3500 MHz 4000 MHz 4500 MHz 5000 MHz 5500 MHz 5990 MHz	Page 1.3	-1	_____	+1	dB	
			Reference		dB	
		-1	_____	+1	dB	
		-1	_____	+1	dB	
		-1	_____	+1	dB	
		-1	_____	+1	dB	
		-1	_____	+1	dB	
		-1	_____	+1	dB	
		-1.2	_____	+1.2	dB	
		-1.2	_____	+1.2	dB	
		-1.2	_____	+1.2	dB	
		-1.2	_____	+1.2	dB	
		-1.2	_____	+1.2	dB	
		-1.2	_____	+1.2	dB	

Characteristic	Included in	Min. value	Actual value	Max. value	Unit	Measurement uncertainty
Attenuator accuracy RF_Att / Ref_Lev : 0 dB / -10 dBm 10 dB / 0 dBm 20 dB / 10 dBm 30 dB / 20 dBm PreAmp = ON (only if PreAmp is implemented) 0 dB / -15 dBm	Page 1.5	-0.5 - -0.5 -0.5 -0.5	 Reference _____	+0.5 - +0.5 +0.5 +0.5	dB - dB dB dB	
IF gain Switching accuracy Reference level -10 dBm -15 dBm -20 dBm -25 dBm	Page 1.5	- -0.5 -0.5 -0.5	 Reference _____ _____ _____	- +0.5 +0.5 +0.5	- dB dB dB	
Displayed average Noise floor f _{noise} : 9.9 MHz 101 MHz 501 MHz 1001 MHz 1501 MHz 2001 MHz 2501 MHz 2999 MHz R&S®FSH6 only : 3501 MHz 4001 MHz 4501 MHz 4999 MHz 5501 MHz 5999 MHz	Page 1.7	- - - - - - - - - - - - - - - -	 _____	-105 -105 -105 -105 -105 -105 -105 -105 -105 -105 -103 -103 -103 -103 -96 -96	dBm dBm dBm dBm dBm dBm dBm dBm dBm dBm dBm dBm dBm dBm dBm dBm	

Characteristic	Included in	Min. value	Actual value	Max. value	Unit	Measurement uncertainty
Displayed average Noise floor with PreAmp = ON (only if PreAmp is implemented)	Page 1.7					
f_{noise} :						
9.9 MHz		-	_____	-120	dBm	
101 MHz		-	_____	-120	dBm	
501 MHz		-	_____	-120	dBm	
1001 MHz		-	_____	-120	dBm	
1501 MHz		-	_____	-120	dBm	
2001 MHz		-	_____	-120	dBm	
2499 MHz		-	_____	-120	dBm	
2999 MHz		-	_____	-115	dBm	
R&S°FSH6 only :						
3501 MHz		-	_____	-115	dBm	
4001 MHz		-	_____	-115	dBm	
4501 MHz		-	_____	-115	dBm	
4999 MHz		-	_____	-115	dBm	
5501 MHz		-	_____	-105	dBm	
5999 MHz		-	_____	-105	dBm	
Phase noise at 500 MHz	Page 1.8					
Offset frequency:						
30 kHz		-	_____	-85	dBc (1Hz)	
100 kHz		-	_____	-100	dBc (1Hz)	
1 MHz		-	_____	-120	dBc (1Hz)	

Characteristic	Included in	Min. value	Actual value	Max. value	Unit	Measurement uncertainty
Display linearity 0 to -30 dB Reference level: 0 dBm Sig_Lev : 0 dBm -5 dBm -10 dBm -15 dBm -20 dBm -25 dBm -30 dBm	Page 1.9	- -0.2 -0.2 -0.2 -0.2 -0.2 -0.2	Reference _____ _____ _____ _____ _____ _____	- +0.2 +0.2 +0.2 +0.2 +0.2 +0.2	- dB dB dB dB dB dB	
Display linearity -30 to -50 dB Reference level: 20 dBm Sig_Lev : -10 dBm -15 dBm -20 dBm -25 dBm -30 dBm	Page 1.9	- -0.3 -0.3 -0.3 -0.3	Reference _____ _____ _____ _____	- +0.3 +0.3 +0.3 +0.3	- dB dB dB dB	

Performance Test Report Tracking Generator

(model 1145.5850.13, 1145.5850.23 or 1145.5850.26 only)

Table 1-2 Performance Test Report

ROHDE & SCHWARZ	Performance Test Report	Option -B9	Version 2 April 2004
Serial number: Test person: Date: Sign:			

Characteristic	Included in	Min. value	Actual value	Max. value	Unit	Measurement uncertainty
R&S°FSH3: Level accuracy output level: -20 dBm Maximum value Minimum value	Page 1.11	-3 -7	_____ _____	+5 -1	dB dB	
R&S°FSH3: Level accuracy output level: 0 dBm (model 1145.5850.23 only) Maximum value Minimum value	Page 1.11	-3 -7	_____ _____	+5 -1	dB dB	
R&S°FSH6: Level accuracy 10 MHz to: 3 GHz Maximum value Minimum value 3 GHz to 6 GHz Maximum value Minimum value	Page 1.11	-2 -5 2 -11	_____ _____ _____ _____	+6 +4 11 6	dB dB dB dB	

2 Adjustment

This chapter describes the adjustment of the software-controlled module data following the replacement of modules.

The R&S FSH permits the following manual adjustments:

- Adjustment of the 10-MHz reference oscillator that determines the frequency accuracy of the R&S FSH.
- Adjustment of the level accuracy of the R&S FSH for different attenuator settings.

Adjustment enables you to maintain and restore the data integrity of the instrument.

Manual adjustments must be performed at an ambient temperature between +20°C and +30°C after the instrument has warmed up.

After the adjustments have been performed, the R&S FSH offers full data integrity. This can be verified by performing the Performance Test as described in Chapter 1.

Verifying the functionality of the R&S FSH is recommended before you start performing adjustments or the performance test. The verification procedure is described in the following section, "Quick Verification".

Quick Verification

The quick verification procedure verifies hardware functionality before full testing can start. Testing of the following is recommended:

- On/off functionality
- Connections of the power adapter and the AF output
- Display
- Level and noise

Measurement Equipment and Accessories for Quick Verification

The quick verification procedure requires a very limited amount of equipment.

Item	Type of equipment	Specifications recommended	Equipment recommended	R&S order no.	Use
1	Signal generator	Frequency: 10 MHz to 3 GHz	R&S SML		Level
2	N-cable	Attenuation: < 0.2 dB to 3 GHz			Tracking generator output level

Verifying on/off functionality

- Test equipment None
- R&S FSH settings Switch instrument ON.
- Measurement ➤ Verify that the instrument switches ON.

Verifying power and AF connections

- Test equipment None
- Accessories AC power adapter
Headphone
- R&S FSH settings Switch instrument ON.
Connect the AC power supply.
- Reference measurement ➤ Verify in the display that the battery symbol changes to a power plug.
- R&S FSH settings Connect the headphone.
- [**Marker** : MARKER DEMOD : **AM**]
- Reference measurement ➤ Verify that a noise signal is heard on the headphone.

Verifying the display

Test equipment	None
R&S FSH settings	Switch instrument ON.
Reference measurement	➤ Check the display for disturbance.

Verifying the level and noise

Test principle	The RF attenuator of the R&S FSH can be switched from 0 to 30 dB by changing the reference level in the instrument.
Test equipment	<ul style="list-style-type: none"> - Signal generator (refer to section "Measurement Equipment and Accessories for Quick Verification", item 1). <li style="padding-left: 20px;">Frequency 100 MHz <li style="padding-left: 20px;">Maximum level ≥ 6 dBm
Test setup	➤ Connect the RF output of the signal generator to the input of the R&S FSH.
Signal generator settings	<ul style="list-style-type: none"> - Frequency 100 MHz - Level - 20 dBm
R&S FSH settings	<ul style="list-style-type: none"> - [PRESET] - [FREQ : 100 MHz] - [SPAN : 10 kHz] - [BW : RES BW MANUAL : 1 kHz] - [BW : VIDEO BW MANUAL : 100 Hz] - [TRACE : DETECTOR : RMS] - [AMPT: 0 dBm]
Verification	<ul style="list-style-type: none"> ➤ Read the level and verify that it shows -20 dBm +/- 2 dB. ➤ Verify that the noise level in the display is < - 60 dBm.
Check 30 dB attenuation	
Change signal generator setting	- Level -30 dBm
Change R&S FSH setting	- [AMPT : -10 dBm]
Verification	➤ Read the level and verify that it shows -30 dBm +/- 2 dB.
Check 10 dB attenuation	
Change signal generator setting	- Level -10 dBm
Change R&S FSH setting	- [AMPT : 10 dBm]
Verification	➤ Read the level and verify that it shows -10 dBm +/- 2 dB.
Check 0 dB attenuation	
Change signal generator setting	- Level 0 dBm
Change R&S FSH setting	- [AMPT : 20 dBm]
Verification	➤ Read the level and verify that it shows 0 dBm +/- 2 dB.

Verify the tracking generator output level

Test principle	The generator output must be connected to the RF input and verified.
Test equipment	None
Test setup	➤ Connect the generator output of the R&S FSH to the RF input.
R&S FSH settings	- [PRESET] - [MEAS : TRACKING GEN :]
Verification	➤ Verify that the level of the sweep shows 0 dB +5 /-7 dB. ➤ <i>Following internal calibration, verify that the level shows 0 +/-1 dB.</i>

Adjustment functions



Caution:

Only qualified personnel should carry out the re-alignment since any change substantially influences the measurement accuracy of the instrument. For this reason, the calibration program is available only on the R&S Service Board.

Adjustment

This section describes the measurement equipment and accessories required for the manual adjustment of the R&S FSH, the appropriate preparations of the equipment, and the individual adjustments.

An adjustment program provides the instructions for the input settings.

Adjustment Instructions

- The adjustment of the analyzer must be performed after a warm-up time of at least 30 minutes. Only by adhering to this requirement can compliance with the guaranteed data be ensured.
- Inputs for setting the R&S FSH during adjustment will be programmed automatically.

Measurement Equipment and Accessories

Item	Type of equipment	Specifications recommended	Equipment recommended	R&S order no.	Use
1	Signal generator	Frequency: 10 MHz to 3 GHz Uncertainty of frequency: 0.1 ppm Phase noise at 500 MHz: < -100 dBc (1Hz) @ 10 kHz < -110 dBc (1Hz) @ 100 kHz < -130 dBc (1Hz) @ 1 MHz	R&S SML		Frequency accuracy of reference oscillator
2	6-dB divider (power splitter)				Frequency response
3	Power meter		R&S NRVD	0857.8008.02	Frequency response
4	Power sensor	1 MHz to 3 GHz RSS ≤ 0.8% Meter noise ≤ 20 pW	R&S NRV-Z4	0828.3618.02	Frequency response

Adjusting the reference frequency accuracy

Test equipment	Signal generator (refer to section "Measurement Equipment and Accessories", item 2)
Test setup	➤ Connect the generator to the RF input.
Generator settings	- Frequency 1 GHz - Level -30 dBm
R&S FSH settings	- [PRESET] - [FREQ : 1 GHz] - [SPAN : 100 kHz] - [BW : MANUAL RES BW : 10 kHz] - [MARKER : MARKER MODE : FREQ COUNT]
Adjustment	The program will adjust the reference oscillator to 10 MHz ± 1 ppm.

Adjusting the level accuracy

- Test equipment
- Signal generator (refer to section "Measurement Equipment and Accessories ", item 1)
 - Power meter (refer to section "Measurement Equipment and Accessories ", item 3)
 - Power sensor (refer to section "Measurement Equipment and Accessories ", item 4)
 - 6-dB power splitter (refer to section "Measurement Equipment and Accessories ", item 2)

Determining the level accuracy at 100 MHz

- Test setup
- Connect the power sensor (item 4) to the power meter and execute function 'ZERO' when there is no signal applied to the power sensor.
 - Connect the RF output of the signal generator to the input of the divider.
 - Connect output 1 of the divider to the power sensor / power meter.
 - Connect output 2 of the divider to the RF input of the R&S FSH.
- Signal generator settings
- Frequency 100 MHz
 - Level 6 dBm
 - Determine the output power of the signal generator with the power meter. Adjust the output power of the generator until the power meter shows the expected level "Ampt". This level is displayed on the PC display during adjustment.
- R&S FSH settings
- Performed automatically via the adjustment program.
- Adjustment
- The program will guide you through the required adjustments for different levels.
- Save calibration data**
- If the measured values are within the programmed limits, the new constants will be automatically stored in the R&S FSH and will be used for future measurements.

Frequency Response Correction

Frequency response correction is part of the RF/IF module and is delivered with the module in an EEPROM. Any change requires the use of a special test program and test setup. If necessary, the module must be sent to R&S Service.

3 Repair

This chapter describes the design of the R&S FSH, simple measures for repair and troubleshooting, and, in particular, the replacement of modules.

Firmware updates and the installation of the DTF option are described in Chapter 4.

Instrument Design and Functional Description

The following figure shows a block diagram of the R&S FSH.

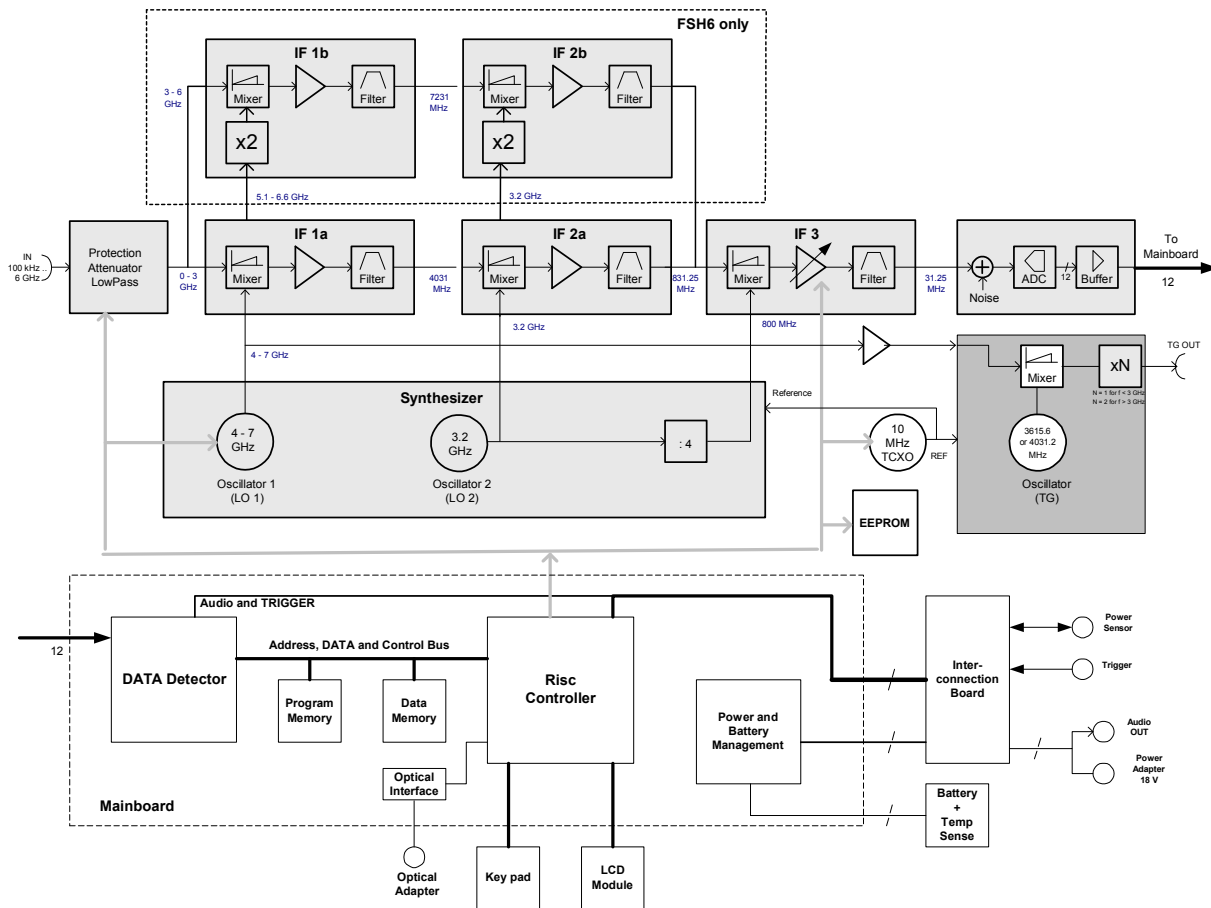

Fig. 3-1 Block Diagram R&S FSH

Description of the block diagram

The R&S FSH is a triple-conversion super-heterodyne receiver for the frequency range 100 kHz to 3 GHz. After signals are received, they are processed by the RF/IF board and the mainboard.

The RF/IF board contains the functions as described below.

Attenuator

The RF signal passes from the input connector RF INPUT to the programmable input attenuator, which can be switched from 0 dB to 30 dB in increments of 10 dB. The circuitry is protected from overvoltage.

RF to IF conversion

The RF/IF board converts the received frequencies in the range 100 kHz to 3 GHz to the low 31.25 MHz IF, which is digitized with 25 MHz before it is sent to the mainboard for digital processing. The RF/IF board also includes the required local oscillators and associated frequency processing circuits. The unit is housed in silver-plated aluminum packaging.

The input signal passes via the input attenuator and the lowpass filter to the first mixer. The lowpass filter provides suppression of the image frequency (image = LO+ IF) to keep the conversion unambiguous. In the 1st mixer the input signal is up-converted to an IF of 4031.25 MHz by means of the first LO (4031.25 MHz to 7031.25 MHz). The mixer is followed by a low noise IF amplifier, which compensates for the loss due to mixing. The signal then passes a filter with a 3-dB bandwidth of approximately 400 MHz for filtering the first IF. The local oscillator frequency required for this conversion is also generated on the board. This signal is generated by three VCOs synchronized to 100 MHz, which in turn is synchronized to a Temperature Compensated 10-MHz Xtal Oscillator (TCXO). This TCXO is electrically calibrated.

The signal from the 1st IF filter is converted to the 2nd IF of 831.25 MHz. The signal is routed to an 831.25 MHz filter with a 3-dB bandwidth of 20 MHz for further signal processing. The filter is followed by the 3rd mixer, which converts to 31.25 MHz and utilizes an IF filter that has a -3-dB bandwidth of approximately 2 MHz.

The frequency range above 3°GHz in the R&S FSH6 is converted via two additional mixers to a first IF of 7231.25°MHz and to the same 2nd IF as in the FSH3 of 831.25 MHz. As LO signals the oscillator signals of the FSH3 are doubled.

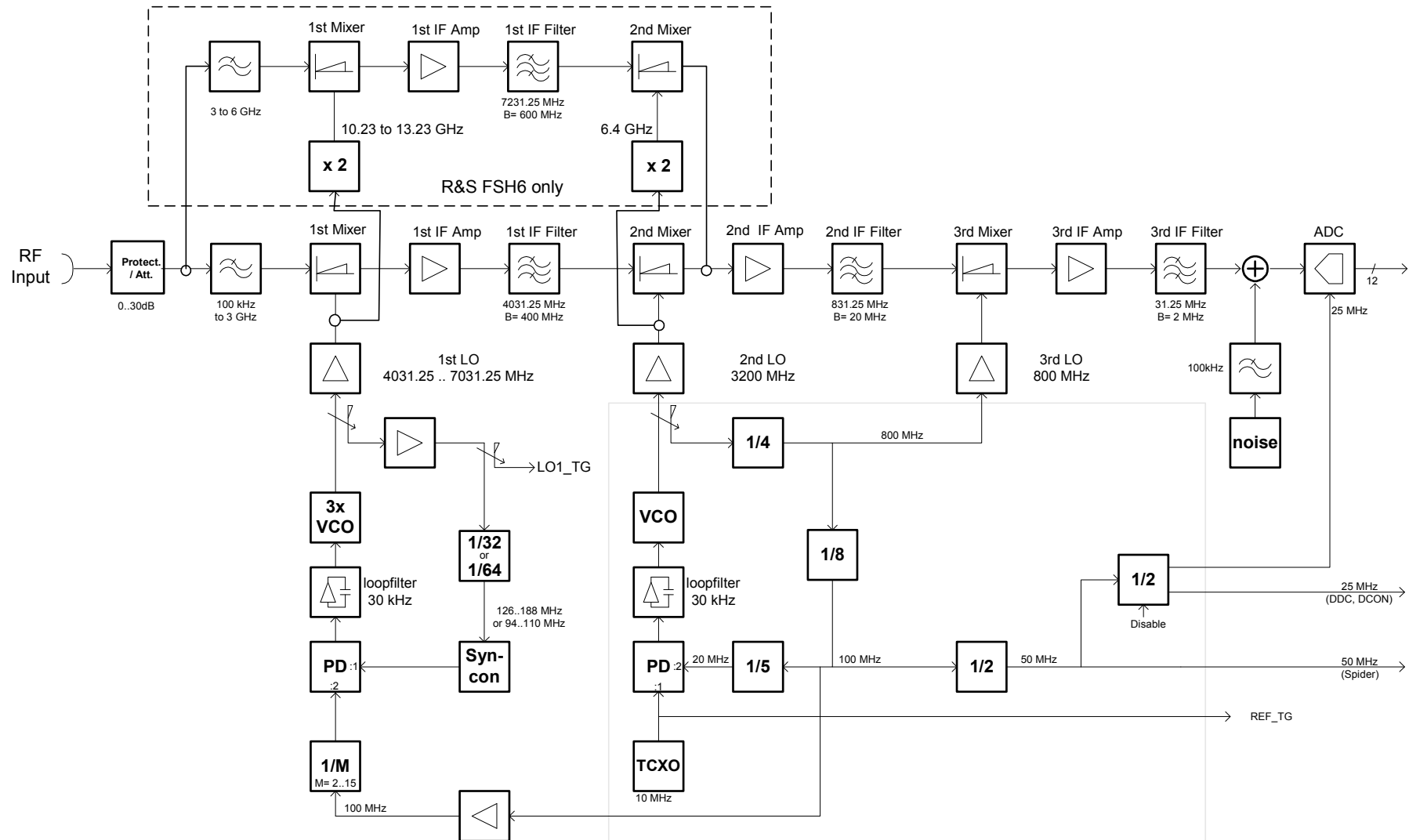

Fig. 3-2 Block Diagram: RF to IF Conversion and Synthesizer

Tracking generator (Model 1145.5850.13/23/26 only)

The LO frequency of the 1st mixer is routed via isolation amplifiers to the TG mixer. The other input of the mixer is a fixed frequency of 4031.25 MHz generated with a VCO locked to the TCXO frequency.

The resulting IF signal is routed to the generator output connector.

RF/IF control

The microcontroller available on the mainboard controls the RF/IF setting by programming registers via an internal serial bus.

For calibration purposes the level correction values are stored in an EEPROM. This EEPROM also contains module-specific information.

The temperature of the module is continuously measured, and the measured levels will be compensated for drift if the temperature change is too great.

Mainboard

The mainboard is a combination of the power supply and the functions controlled by a dedicated RISC controller (ARM 720).

Power and battery management

The ON/OFF key is de-bounced with the real-time clock in the controller. The ON/OFF function is completely software controlled. This implies that the controller must be operational in order for the instrument to be switched ON. The μ P-clock (50 MHz) is derived from the RF/IF board, thus requiring that this board be present. This frequency will always be present if the power adapter is connected or the instrument is in the ON state.

If the instrument is in the OFF state and the power supply is connected, the μ P will control the charging function of the battery depending on the battery condition. The maximum charging current is 1000 mA, which drops to a trickle charge of about 100 mA if the battery is fully loaded. To prevent damage to the battery, the charging stops if the battery temperature reaches $\leq 0^{\circ}\text{C}$ or $> 45^{\circ}\text{C}$. In the OFF state, the charging current is approximately 90 mA.

This power supply and battery management arrangement uses a dedicated IC. The instrument can be switched ON only if the battery is in operating condition. Thus, if the battery is completely empty, the instrument cannot be switched ON until the charging current has re-loaded the battery, which takes several minutes.

Processing of measured data detectors

The measured data is processed in two dedicated ICs to reduce the sample rate of the input signal to a value that can be handled by the hardware. The DDC converts the digital IF signal to I/Q base band and filters the base band signals using low pass filters with programmable bandwidth. In addition it delivers the AM or FM demodulated audio signal. The DCON Asic detects the envelope of the filtered and combined base band signal and calculates its logarithm. It contains also the video filter and the different detectors. In addition it is responsible for the sweep control of the FSH.

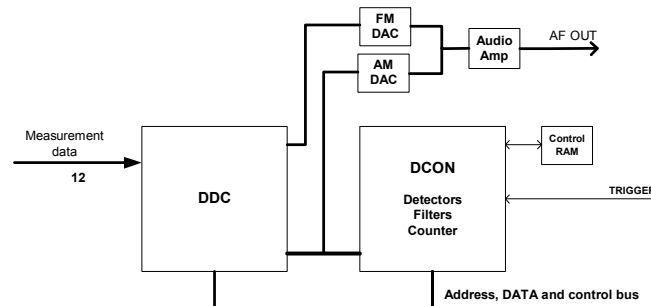

Fig. 3-3 Measured Data Processing

Resolution bandwidths (RBW)

The resolution bandwidths are implemented in the R&S FSH through digital processing in the DDC ASIC (Digital Down Converter). The RBW can be selected from within the range 1 kHz to 1 MHz in 1-, 3- or 10-unit increments. The DDC first mixes its input IF to the baseband using an NCO (Numeric Controlled Oscillator) and then filters the resulting IQ signals via a combination of HDF (High Decimation Filter) and an FIR (Finite Impulse Response) stages. At the end of the DDC processing chain, the IQ signal is split into magnitude and phase.

For AF demodulation the amplitude information is used. In the case of FM the phase information is used and fed to the headphone connector. In the analyzer mode the signal at the position of the marker can be demodulated. In this case the R&S FSH stops the sweep for a selectable period of time and demodulates the input signal. The volume can be adjusted.

For a standard log display of the analyzed spectrum, the magnitude data is converted from linear to logarithmic in the DCON ASIC (Digital Controller).

Video bandwidths (VBW)

The video filters can be adjusted between 10 Hz and 3 MHz in increments of 1/3/10. They are designed as digital lowpass filters for the video signals in the DCON ASIC. Software can couple the VBW to the RBW, or the VBW can be set independently.

Detectors

The R&S FSH uses a detector for the positive peak and the negative peak value. In the “sample” mode the measured value is routed directly to the display. In the RMS mode the detector determines the rms value of the input signal for one specific point in the display during the measured time.

Keypad control

Keypad control is a dedicated function of the controller. For the implementation of the rotary knob, an encoder is used that is detected with a dedicated CPLD (Complex Programmable Logic Device). This “One Time Programmable” CPLD is programmed during production.

Serial optical interface

The interface to an external PC has been implemented with optical technology to avoid electrical loops. The protocol is RS-232-based and is implemented in the instrument by the UART of the controller. It requires a special optical RS-232 cable for communication (R&S FSH-Z34, delivered with the instrument). The maximum baud rate is 115200.

Power sensor

The power sensor uses the display of the R&S FSH. Communication is achieved with a separate UART from the controller.

Color LCD module

The ¼ VGA passive matrix display is backlit by an FCC backlight, whose light output can be adjusted to an optimum between visibility and battery use.

Module Replacement

This section describes the service concept and contains the spare parts list and the basic documents for the R&S FSH instrument.

Note: The numbers indicated in brackets refer to items in the mechanical exploded drawings.

Note: The words “left” and “right” in the manual always refer to the front view of the instrument.



Caution!

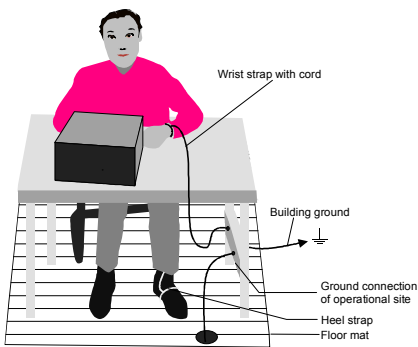

- Please pay close attention to the safety instructions in the front section of this manual.
- Disconnect the power connector from the instrument before opening the case.
- Safeguard the replacement site against electrostatic discharge to prevent damage to electronic components of the modules.
- The following two methods of ESD protection can be used together or separately:
 - Wrist strap with cord to ground connection
 - Conductive floor mat and heel strap combination

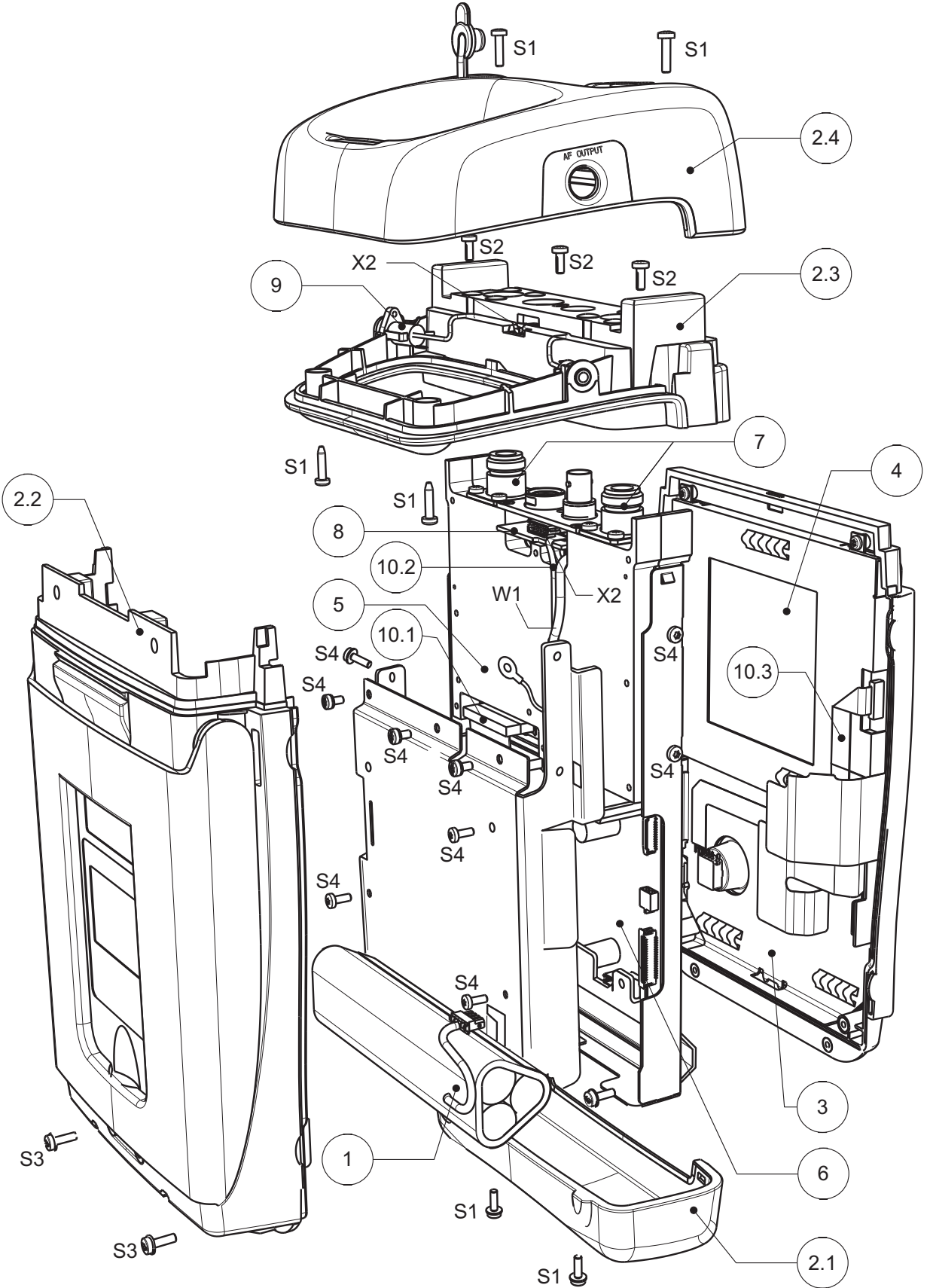

Fig. 3-4 Exploded View

Overview of the modules

Table 3-1 List of spare parts and order numbers

Reference	Part	R&S Order Number
1	Battery Pack for R&S FSH (R&S FSH-Z32)	1145.5796.02
2	Housing R&S FSH without top holster	1157.3258.00
2.4	Top holster for FSH without tracking generator	1157.3487.00
	Top holster for FSH with tracking generator	1157.3493.00
3	Front unit for R&S FSH3	1157.3241.00
	Front unit for R&S FSH6	1300.7591.00
4	LCD module	1157.3229.00
	LCD plane for FSH3	1300.7704.00
	LCD plane for FSH6	1300.7710.00
5	RF/IF module for R&S FSH3 without tracking generator	1157.3606.00
	RF/IF Module for R&S FSH3 with tracking generator	1157.3612.00
	RF/IF Module for R&S FSH6 without tracking generator	1300.7604.00
	RF/IF Module for R&S FSH6 with tracking generator	1300.7610.00
6	Mainboard for R&S FSH	1157.3570.00
7	N connector	1157.3235.00
8	Interconnection board	1157.3587.00
9	Input unit (power and audio connectors, including wire tree)	1157.3270.00
10	Set of cables for R&S FSH	1157.3329.00
21	AC mains adapter for R&S FSH (EU Version)	1157.3293.00
22	AC mains adapter for R&S FSH (UK Version)	1157.3306.00
23	AC mains adapter for R&S FSH (US Version)	1157.3312.00
	AC mains adapter for R&S FSH (AUS Version)	1157.3370.00

See exploded drawing on the previous page.

Opening the instrument

(See exploded drawing for related numbers.)

- Disconnect the power plug.
- Switch the instrument to OFF.
- Loosen the six (S1) screws and remove the top cover (2.4) and bottom cover (2.1).
- Disconnect the connector (X2).
- Loosen the three (S2) screws and remove the grip cover (2.3).
- Loosen the two (S3) screws and remove the rear case (2.2).
- Loosen the nine (S4) screws and remove the mainboard shielding.

Closing the instrument

- Mount the mainboard shielding and fasten the nine (S4) screws.

Note that the shielding of wire-tree (W1) is reconnected again.

- Mount the rear case (2.2) and fasten the two (S3) screws.
- Mount the grip cover and fasten the three (S2) screws.
- Connect the connector (X2).
- Mount the top cover (2.4) and bottom cover (2.1).
- Fasten the six (S1) screws .
- Perform the quick verification test.

Refer to Chapter 2 "Adjustment".



Caution!

Note that the connecting cables are still connected.

- **Note:** When detaching the connectors, proceed with caution.

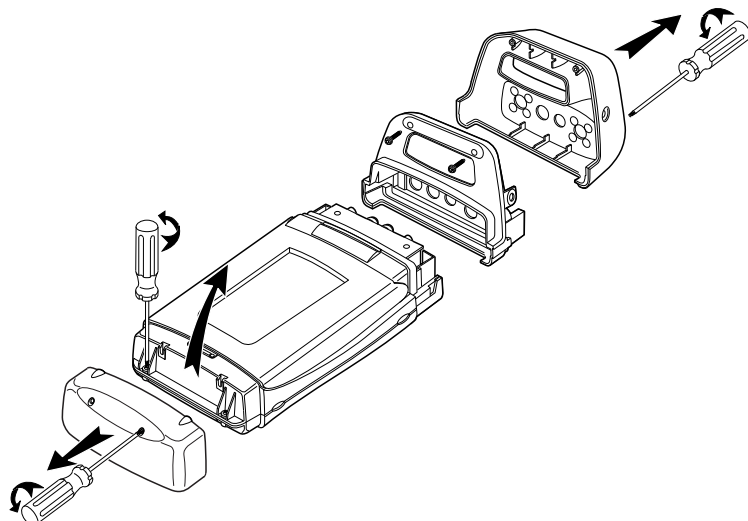

Fig. 3-5 Opening the instrument

Replacing the battery

- Open the instrument.
- Disconnect connector (X1).
- Replace the battery.
- **Caution:**
In order to avoid shortening the battery contacts, a plastic screwdriver or a screwdriver with a plastic cover over its metal top must be used when pushing the battery connector (X1) in place.
- Connect (X1).
- Close the instrument.
- Charge the battery.
- Perform the quick verification test.
Refer to Chapter 2 "Adjustment".
- **Note:** *It is recommended that battery charging be performed with the instrument switched OFF and the AC power connected to the mains. The charging time for a full battery is about 4 hours.*

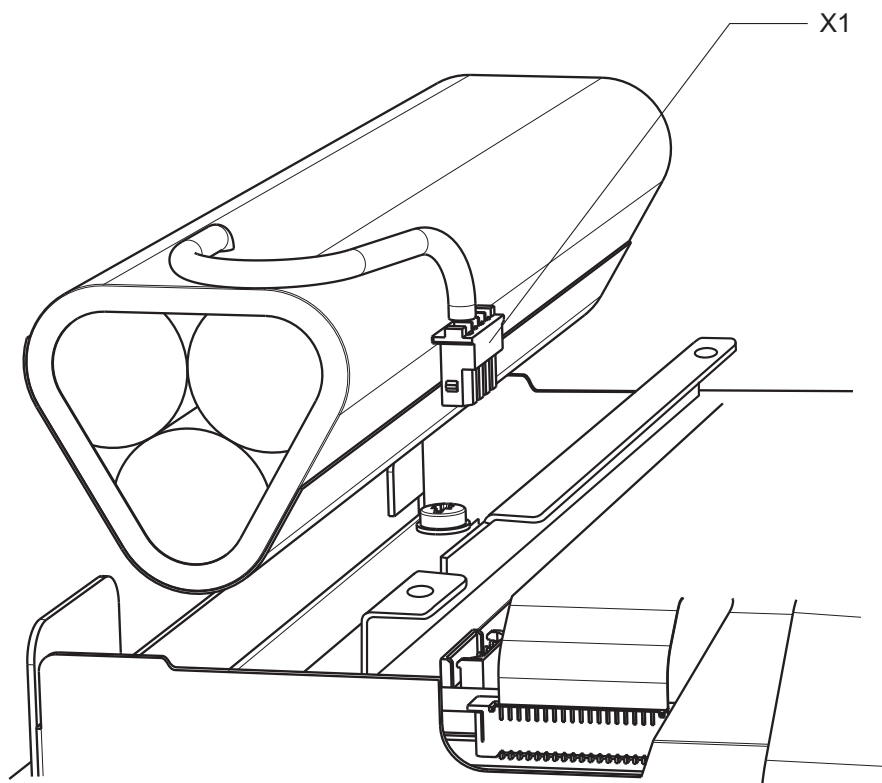

Fig. 3-6 Replacing the battery

Replacing the housing

Housing parts:

- 2.1: Bottom cover
- 2.2: Rear case
- 2.3: Grip cover
- 2.4: Top cover

Notes: When replacing the rear case, the existing type plate must be placed on the new rear case, or the old series number must be written on the new type plate.

When the grip cover is replaced, the “input unit power/audio connections” have to be placed in the new grip cover. See also Replacing the power/audio connections.

- Open the instrument.
 - Replace the specific housing part.
 - Close the instrument.
 - Perform the quick verification test.
- Refer to Chapter 2 “Adjustment”.

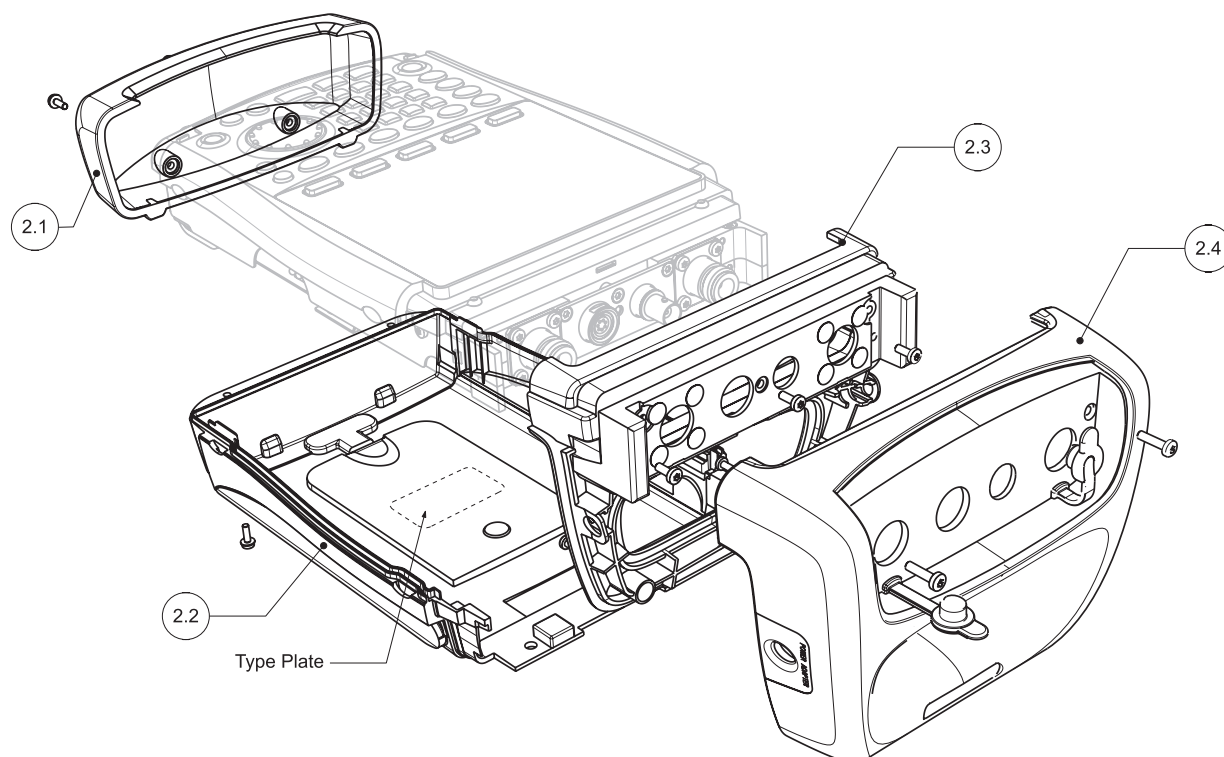

Fig. 3-7 Replacing the housing

Replacing the front unit for R&S FSH

- Open the instrument.
- Remove the battery .
- Remove the Main Unit:
 - Disconnect the connectors (X3), (X4), and (X5).
 - Remove the main unit by unscrewing the two (S5) screws.
- Remove the LCD colour module:
 - Losen the four (S6) screws.
 - Remove the LCD colour module.
- Use the new front unit to assemble the instrument again.



Before mounting the unit, make sure that no dust is present between the front unit and the LCD colour module.

- Mount the LCD colour module with the four (S6) screws.
 - Mount the Main Unit with the two (S5) screws.
 - Connect the connectors (X3), (X4), and (X5).
 - Mount the battery.
 - Close the instrument.
 - Perform the quick verification test.
- Refer to Chapter 2 “Adjustment”.*

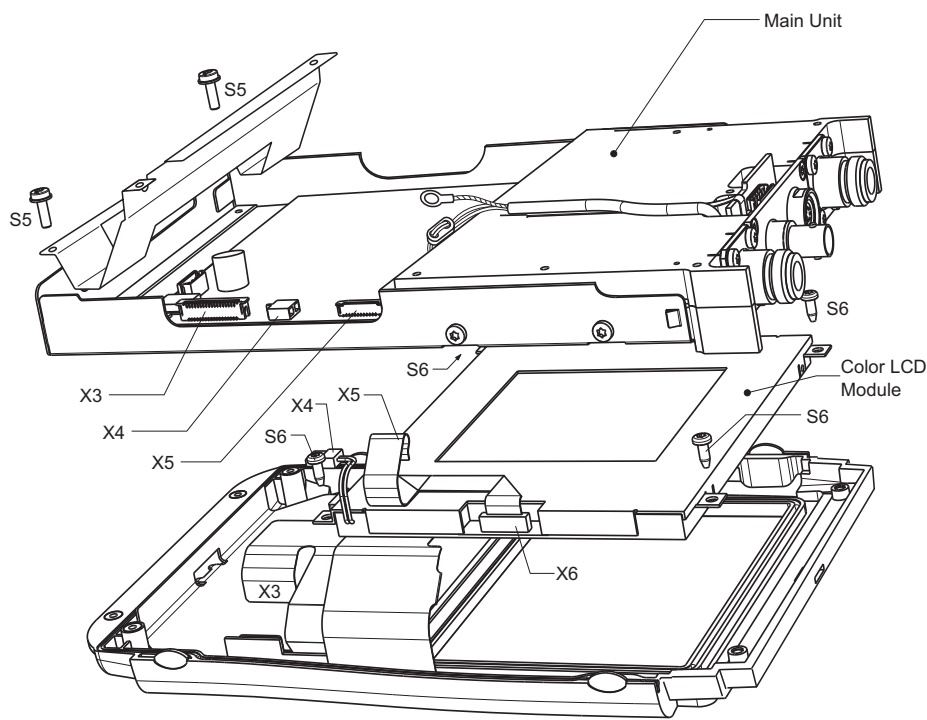

Fig. 3-8 Replace Front Unit

Replacing the Color LCD Module

- Open the instrument.
- Remove the battery
- Remove the Main Unit:
 - Disconnect the connectors (X3), (X4), and (X5).
 - Remove the main unit by unscrewing the two (S5) screws.
- Remove the LCD colour module:
 - Disconnect the connector (X6).
 - Loosen the four (S6) screws.
 - Remove the LCD colour module.
- Use the new module to assemble the instrument again.



Before mounting the unit, make sure that no dust is present between the front unit and the colour module.

- Mount the LCD colour module with the four (S6) screws.
- Mount the Main Unit with the two (S5) screws.
- Connect the connectors (X3), (X4), and (X5).
- Mount the battery.
- Close the instrument.
- Perform the quick verification test.

Refer to Chapter 2 "Adjustment".

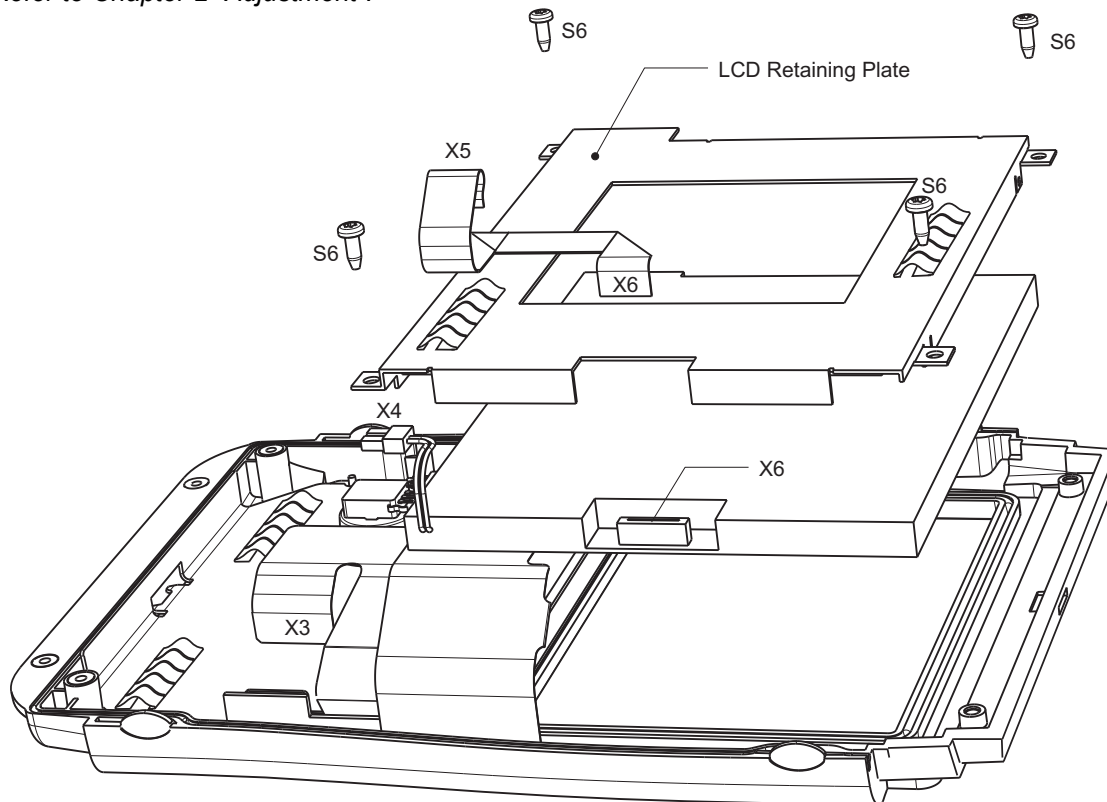

Fig. 3-9 Replacing the Color LCD Module

Replacing the RF/IF module

- Open the instrument.
- Disconnect the flat cable (X8) and remove the tape.
- Disconnect the connectors (X7) and (X9).
- Remove the RF/IF module by unscrewing (S7).
- Remove the binder and BNC connector block:
 - Loosen the four (S8) screws.
 - Remove the connector block.
- Mount the new RF/IF module.
- Mount the binder and BNC connector block with the four (S8) screws.
- Connect connectors (X7) and (X9).
- Mount the flat cable (X8), including the ferrite.
- Fasten the flat cable with the tape.
- Close the instrument.
- Perform the manual adjustment.

Refer to Chapter 2 "Adjustment".

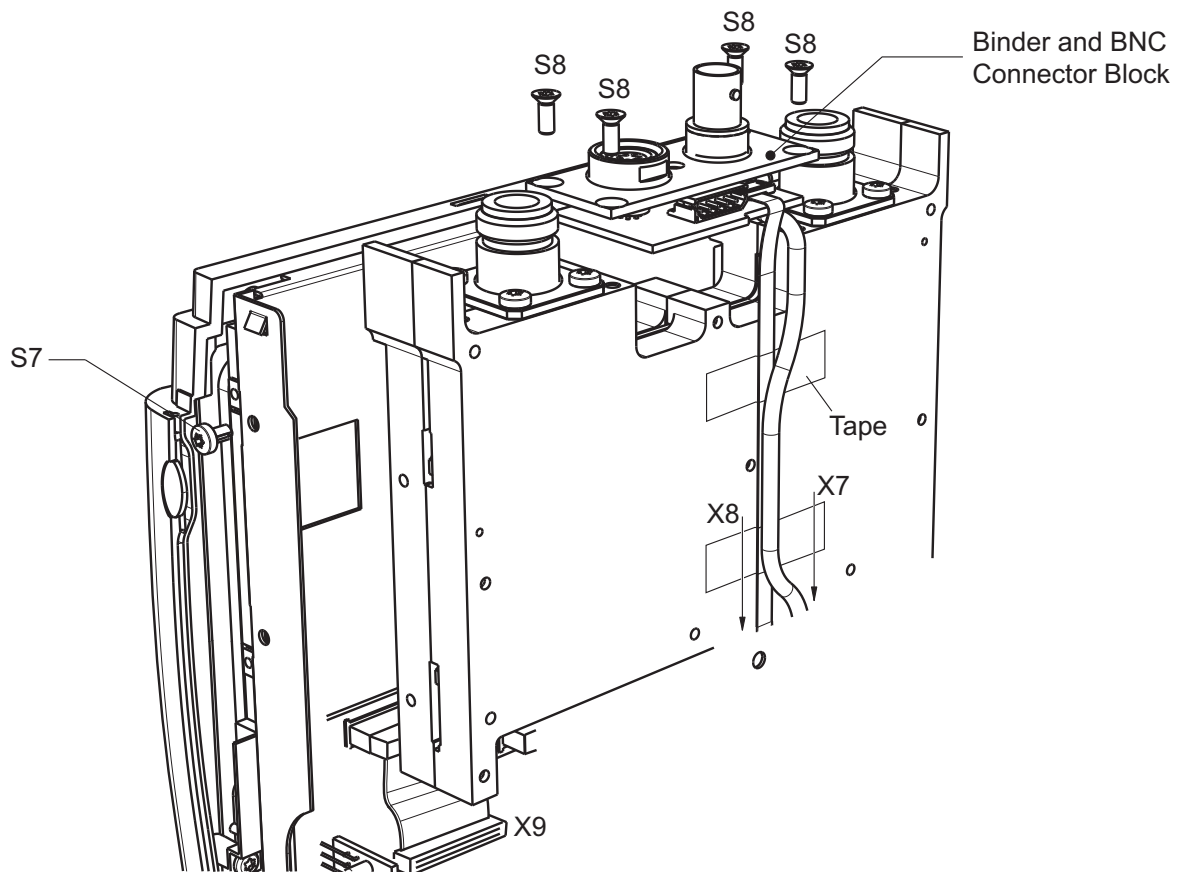

Fig. 3-10 Replacing the RF/IF Module

Replacing the mainboard

The mainboard contains information about the instrument like the serial number. Special tools are necessary to update this information after replacement of the mainboard. Therefore the exchange of the mainboard is possible in a R&S Service Center, only.

- Open the instrument.
- Remove the battery.
- Loosen the two (S5) screws.
- Disconnect the connectors (X3), (X4), (X5), (X7), (X8) and (X9).
- Loosen the three screws (S11) and the remove the board.

Note that the two lower screws are isolated.

- Remove the distance screw (S12)
- Mount the new board and fasten (S11) and (S12).
- Connect connectors (X3), (X4), (X5), (X7), (X8) and (X9).
- Mount the Battery.
- Close the instrument.
- Perform the manual adjustment.

Refer to Chapter 2 "Adjustment".

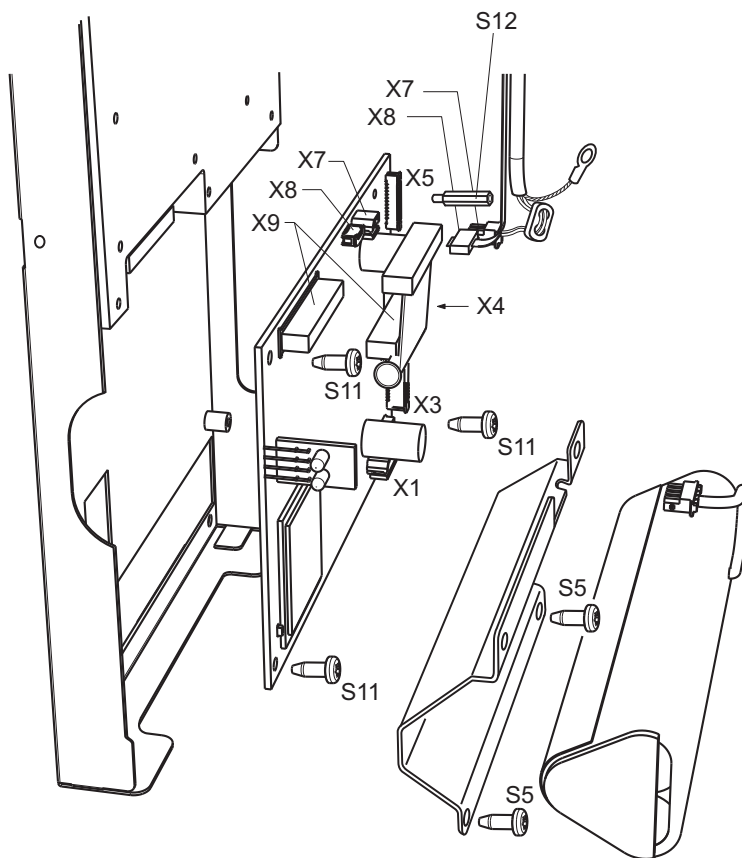

Fig. 3-11 Replacing the Main Board

Replacing the N connector

- Open the instrument.
 - Remove the battery.
 - Remove the RF/IF module by unscrewing (S7).
 - Disconnect the flat cable (X8).
 - Disconnect the connectors (X7) and (X9).
 - Remove the binder and BNC connector block:
 - Loosen the four (S8) screws.
 - Remove the connector block.
 - Loosen the two screws (S9) from front RF housing for each N connector.
 - Loosen the 9 screws (S10) from the RF housing.
 - Remove the front RF housing.
 - Clean the center contact of solder left from the N connector to be replaced.
 - Loosen the other two screws (S9) from the appropriate N connector.
 - Mount the new connector by first screwing it into the rear RF housing.
 - Solder the center connection.
 - Mount the front RF housing (S10).
 - Fasten the two screws (S9) to the front RF housing for each the N connector.
 - Mount the binder and BNC connector block with the (S8) screws.
 - Mount the flat cable (X8), including the ferrite.
 - Connect the connectors (X7) and (X9).
 - Mount the RF/IF module (S7).
 - Mount the Battery and close the instrument.
 - Perform the manual adjustment.
- Refer to Chapter 2 "Adjustment".*

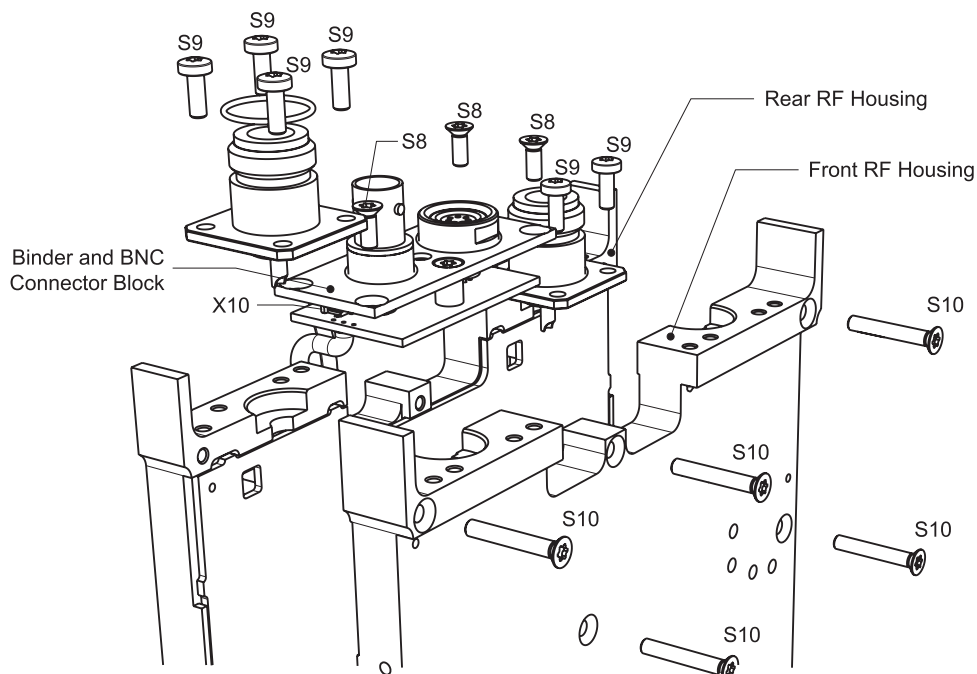

Fig. 3-12 Replacing the N-Connector

Replacing the binder and BNC connector block

(See exploded view for references).

- Open the instrument.
- Disconnect the flat cable (X10).
- Disconnect the connector (X7).
- Remove the binder and BNC connector block:
 - Loosen the four (S8) screws.
 - Remove the connector block.
- Mount the binder and BNC connector block with the four (S8) screws.
- Connect the connectors (X7).
- Mount the flat cable (X10).
- Close the instrument.
- Perform the quick verification test.

Refer to Chapter 2 "Adjustment".

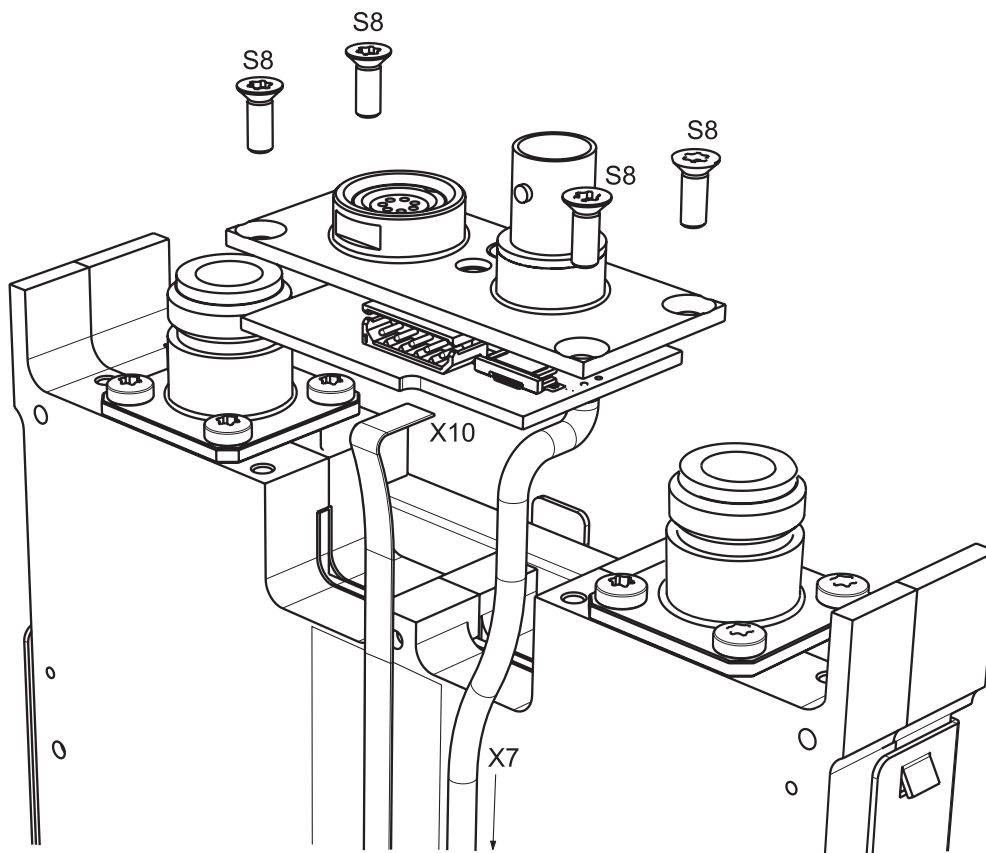

Fig. 3-13 Replacing the Binder and BNC connector block

Replacing the power/audio connections

- Remove the top cover.
- Disconnect the connector (X2)
- Remove the connection wire tree from the grip cover.
- Mount the wire tree again.
- Mount the top cover.
- Perform the quick verification test.

Refer to Chapter 2 "Adjustment".

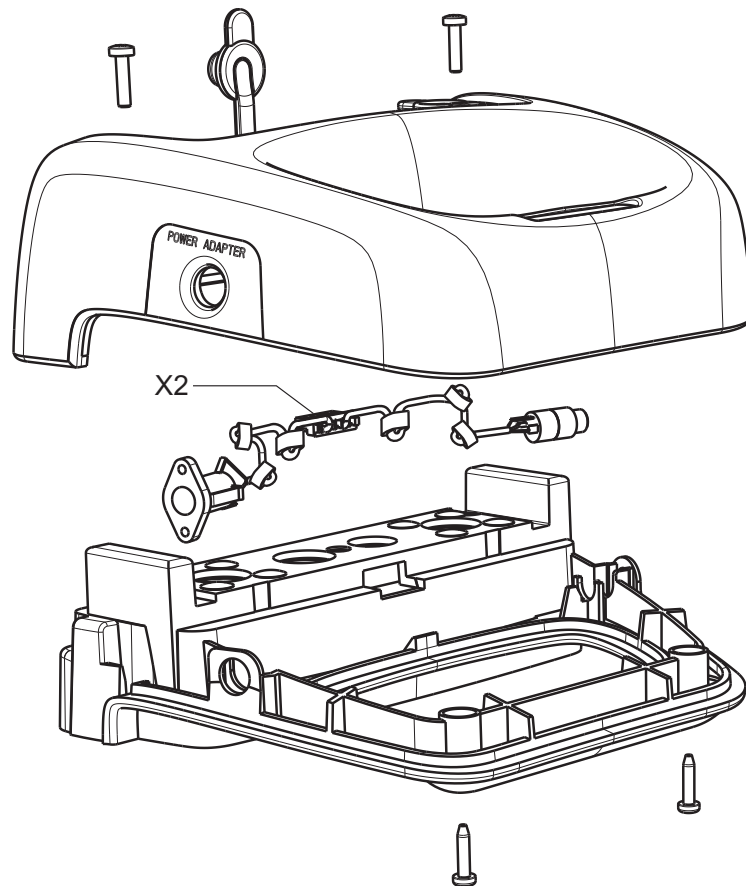

Fig. 3-14 Replacing the Power/ Audio Connections

Replacing a cable from the cable set

Note: The cable set is needed in the event that a cable is damaged during the replacement of one of the modules.

Cables from the set:

- 10.1: 50-p
- 10.2: Flat flexible cable, 8 connections
- 10.3: Flat cable 22-p

For replacement instructions, refer to the individual modules.

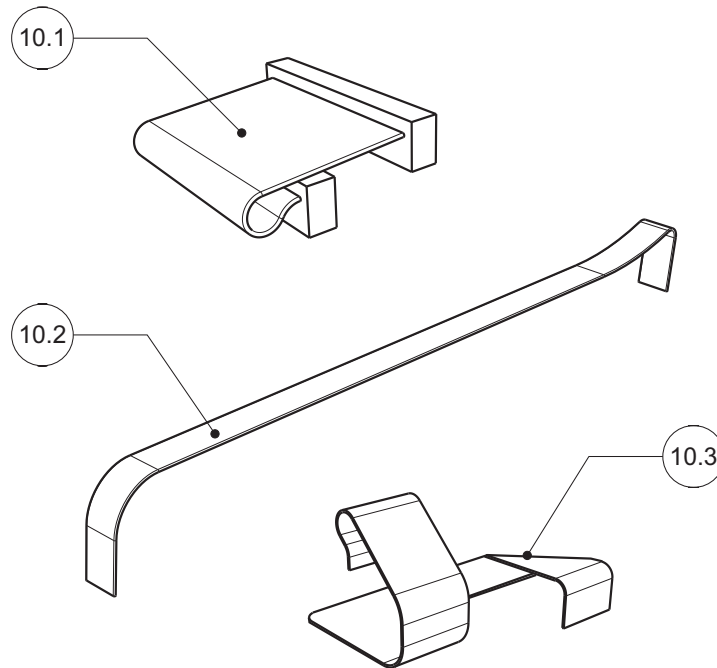

Fig. 3-15 Cable set

Troubleshooting

Malfunctions can have simple causes but can also be due to faulty components or modules.

These troubleshooting instructions can be used to locate causes of error down to the board level and to return the instrument to operability by replacing boards.

We recommend that the instrument be shipped to our experts at the service centers (refer to address list) for module replacement and further error correction.



Warning! *Do not plug or unplug boards without first disconnecting the battery and the AC Power Supply!*

Note: *When problems occur, first check whether any connections (cables, plug-in connections of boards, etc) are damaged or incorrectly connected.*

Overview of errors, causes, and possible corrective actions

This section lists various errors, the probable module causing the problem, and the suggested corrective action.

Troubleshooting problems in switching on the instrument

- **Error: R&S FSH cannot be switched on.**

Note: *When the instrument is switched on, a beep is issued to indicate that the instrument has started.*

Troubleshooting procedure	Possible cause of error and further steps
Verify that the AC power is present. ↓	Connect the adapter to the mains and wait several minutes until the charger has recharged the battery.
Press the On button for > 5 s. ↓	This will force the instrument to perform a software reset and a reset of the internal RAM. The instrument firmware will restart and all data will be reset.
Open the instrument and check the battery. ↓	Voltage > 7.2 V.
Check the connectors from the AC power supply: X2 and X7 (refer to section "Repair").	Power connector broken. <i>Replace the power and audio connections. Replace the mainboard (refer to "Replacing the module").</i>

- **Error: Display remains dark although the beep indicated that the software was started.**

Troubleshooting procedure	Possible cause of error and further steps
Open the instrument and check X4 (backlight connector).	Backlight connection open or backlight converter broken. <i>Connect again, or replace the mainboard or LCD colour module.</i>

- **Error: Display has erroneous colours and characters.**

Troubleshooting procedure	Possible cause of error and further steps
Open the instrument and check X5 and X6 (LCD data).	Data connection broken, or circuitry on the mainboard defective. <i>Connect again, or replace the mainboard or LCD colour module</i>

- **Error: Frequency response not compliant with specification.**

This response can only be corrected at the service center. **Replace the RF/IF module.**

- **Error: Level display very noisy.**

Troubleshooting procedure	Possible cause of error and further steps
Check the N connector. ↓	The N connector is soiled. <i>Clean or replace the N connector.</i> <i>Replace the RF/IF module.</i>

- **Error: Several keys on the keypad do not respond.**

Troubleshooting procedure	Possible cause of error and further steps
Check X3.	The connection is not operational or the keypad is broken. <i>Correct the connection, or replace the front unit.</i>

- **Error: Power sensor does not respond properly.**

Troubleshooting procedure	Possible cause of error and further steps
Check X8 and X10.	The connection is not operating correctly, the binder connector is broken, the mainboard is broken, or the cables are broken. <i>Correct the connection.</i> <i>Replace the binder and BNC connector block.</i> <i>Replace the mainboard.</i> <i>Replace any broken cable in the cable set.</i>

4 Software Updates / Installing Options

This chapter provides information on software updates and how to install options on the R&S FSH. Additional manuals supplied along with software/firmware updates or with options obtained later can be recorded here.

Installing New R&S FSH Software

A new firmware version can be installed via the R&S website. You can download the newest software version, and the new software can be loaded onto the R&S FSH by using the setup program.

The instructions are included in the program.

Installing the Options

The following options are available with the R&S FSH:

Distance to Fault Measurement for R&S FSH	R&S FSH-B1	1145.5750.02
Remote Control via RS-232-C	R&S FSH-K1	1145.3458.02
Vector Transmission and Reflection Measurements	R&S FSH-K2	1145.3387.02

5 Documents

This chapter provides information on how to order spare parts, and it also contains the spare parts list.

Shipping of Instrument and Ordering of Spare Parts

Please contact your Rohde & Schwarz support center or our spare parts express service if you need to request service, repair your equipment, or order spare parts and modules.

The list of Rohde & Schwarz representatives and the address of our spare parts express service are provided in the front section of this service manual.

You will need to provide the following information in order for us to respond to your inquiries quickly and accurately and to determine whether the warranty for your instrument is still valid:

- Instrument model
- Serial number
- Detailed error description in case of repair
- Contact partner for checkbacks

Shipping of instrument

When shipping the instrument, be sure to provide sufficient mechanical and anti-static protection:

- Repack the instrument as it was originally packed. The antistatic packing foil prevents unintentional electrostatic charging from occurring.
- If you do not use the original packaging, include sufficient padding to prevent the instrument from slipping inside the package. Wrap antistatic packing foil around the instrument to protect it from electrostatic charging.

Shipping of a module

When shipping a module, be sure to provide sufficient mechanical and antistatic protection:

- Ship the module in a sturdy, padded box.
- Wrap the board in antistatic foil.
If the packaging is antistatic but not conductive, additional conductive packaging is required. The additional packaging is not required if the enclosed packaging is conductive.

Ordering spare parts

To deliver replacement parts promptly and correctly, we need the following information:

- R&S order number (refer to the spare part lists in this chapter)
- Designation
- Number of units
- Instrument type for the replacement part
- Contact person for possible questions

The R&S order number to be used when ordering replacement parts and modules as well as power cables can be found further below.

Refurbished modules

- Refurbished modules are an economical alternative to original modules. It should be kept in mind that refurbished modules are not new, but repaired and fully tested parts. They may have signs of use but they are electrically and mechanically equivalent to new modules.
- To find out which refurbished modules are available, please contact your Rohde & Schwarz representative (or the central service division at Rohde & Schwarz in Munich).

Return of defective replaced modules

- Defective modules of the replacement program that can be repaired may be returned within **3 months** after delivery of the replaced module. A repurchasing value is credited.
- Excluded are parts that cannot be repaired, e.g. PCBs that are burned, broken or damaged by repair attempts, incomplete modules, or parts that have endured heavy mechanical damage.
- Defective parts must be sent back with an **accompanying document of returned items** containing the following information:
 - R&S order number, serial number and designation of the removed part
 - **Precise** description of the error
 - R&S order number, serial number and designation of the instrument the part was removed from
 - Date of part removal
 - Name of the technician who exchanged the part
- A **document of returned items** is provided along with each replacement module.

Spare Parts

The R&S Order numbers necessary for ordering replacement parts and modules can be found in the spare part lists provided below.

List of R&S FSH spare parts

The following table lists available spare parts together with their R&S order numbers.

Reference	Part	R&S Order Number
1	Battery Pack for R&S FSH (R&S FSH-Z32)	1145.5796.02
2	Housing R&S FSH without top holster	1157.3258.00
2.4	Top holster for FSH without tracking generator	1157.3487.00
	Top holster for FSH with tracking generator	1157.3493.00
3	Front unit for R&S FSH3	1157.3241.00
	Front unit for R&S FSH6	1300.7591.00
4	LCD module	1157.3229.00
	LCD plane for FSH3	1300.7704.00
	LCD plane for FSH6	1300.7710.00
5	RF/IF module for R&S FSH3 without tracking generator	1157.3606.00
	RF/IF Module for R&S FSH3 with tracking generator	1157.3612.00
	RF/IF Module for R&S FSH6 without tracking generator	1300.7604.00
	RF/IF Module for R&S FSH6 with tracking generator	1300.7610.00
6	Mainboard for R&S FSH	1157.3570.00
7	N connector	1157.3235.00
8	Interconnection board	1157.3587.00
9	Input unit (power and audio connectors, including wire tree)	1157.3270.00
10	Set of cables for R&S FSH	1157.3329.00
21	AC mains adapter for R&S FSH (EU Version)	1157.3293.00
22	AC mains adapter for R&S FSH (UK Version)	1157.3306.00
23	AC mains adapter for R&S FSH (US Version)	1157.3312.00
	AC mains adapter for R&S FSH (AUS Version)	1157.3370.00

Note: *The reference can be found in the exploded drawing in Chapter 3.*



Important Note!

When replacing a module, please pay careful attention to the safety instructions and the repair instructions provided in chapter 3 and at the beginning of this service manual.

When shipping a module, be sure to provide sufficient mechanical and antistatic protection.
